

LUX ELEMENTS®-TUB-RSE

Montageanleitung
Instructions for assembly
Instruction de montage
Montagehandleiding



D

LUX ELEMENTS GmbH & Co. KG
An der Schusterinsel 7
D - 51379 Leverkusen-Opladen

Tel. +49 (0) 21 71/72 12-0
Fax +49 (0) 21 71/72 12-40

E-Mail info@luxelements.de
Web www.luxelements.com

F

LUX ELEMENTS S.A.S.
ZI-31, rue d'Ensisheim
F - 68190 Ungersheim

Tél. +33 (0) 3 89 83 69 79
Fax +33 (0) 3 89 48 83 27

E-Mail info@luxelements.fr
Web www.luxelements.fr

FACHVERBAND
FLIESEN
UND NATURSTEIN
im Zentralverband des Deutschen Bauwesens

FECAMC

Systèmes
Céramiques

CONNEXION
CARRELAGE

EUF

VSPH
ASCC
ASCP

BYGGKERAMIKKFORENINGEN

D Bitte beachten Sie ...

... unsere Datenblätter, die weitere technische Informationen zur Montage und Verlegung von Belagsmaterialien enthalten. Sie können diese kostenlos von unserer Homepage herunterladen. Generell empfehlen wir bei einer Verlegung von Mosaik von < 5 x 5 cm eine Verklebung und Verfugung mit Reaktionsharz.

GB Please observe ...

... our data sheets. These contain further technical information regarding the assembly and installation of cladding materials. You may download them free of charge from our homepage. We generally advise for tiles < 5 x 5 cm to use epoxy for gluing and grouting.

F Veuillez tenir compte ...

... de nos fiches techniques qui contiennent de plus amples informations techniques sur le montage et la pose des matériaux de revêtement. Vous pouvez les télécharger gratuitement sur notre site internet. Pour la mise en oeuvre de mosaïque d'un format < 5 x 5 nous conseillons un collage et un jointoyement à l'époxy.

NL Gelieve op ...

... onze gegevensbladen te letten. Deze bevatten verdere technische informatie m.b.t. plaatsing van afdekmaterialen. U kan deze kosteloos van onze internetpagina downloaden. Algemeen adviseren wij bij het kleven en het voegen van mosaik < 5 x 5 cm een epoxylijm te gebruiken.

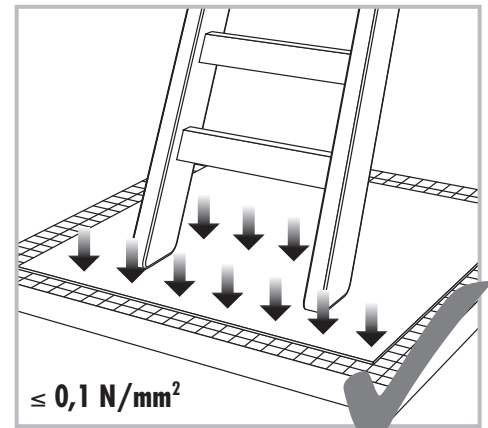
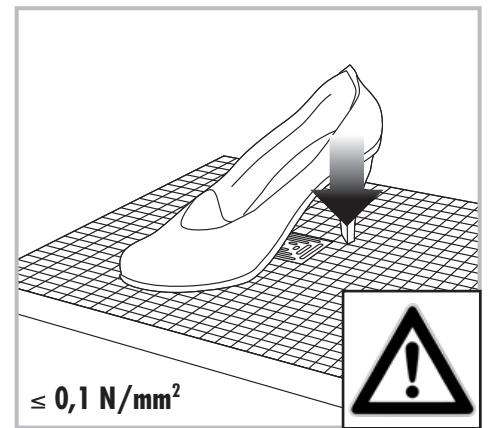

D Falls notwendig, lässt sich der Abflaupf mit Hilfe eines Hebels (z. B. Schraubendreher) wieder vom Aufnahmerahmen trennen (siehe Skizze).

GB If necessary, the drain pan may be removed from the attachment frame with the aid of a lever (i.e. screwdriver – please see drawing)

F Si nécessaire, le siphon de sol peut être séparé au moyen d'un levier (p.ex. tournevis), du cadre de réception (voir esquisse).

NL Indien nodig, is de afvoerpot met behulp van een hefwerktuig (b.v. schroevendraaier) weer scheidbaar van het ingebouwde montagearaam (zie schets).

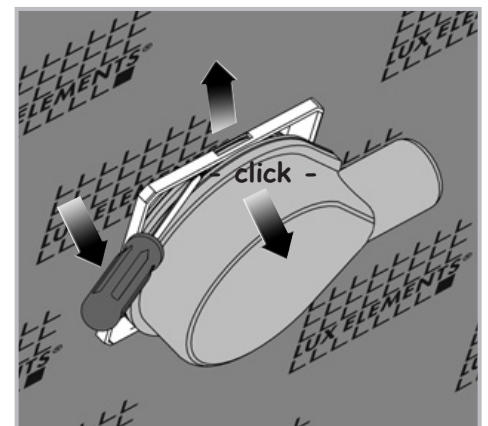

Herstellung einer Abdichtung im Verbund mit Fliesen- und Plattenbelägen unter Einsatz von LUX ELEMENTS®-TUB als Abdichtungssystem gemäß Bauregelliste A Teil 2, lfd. Nr. 1.10 Beanspruchungsklasse A2

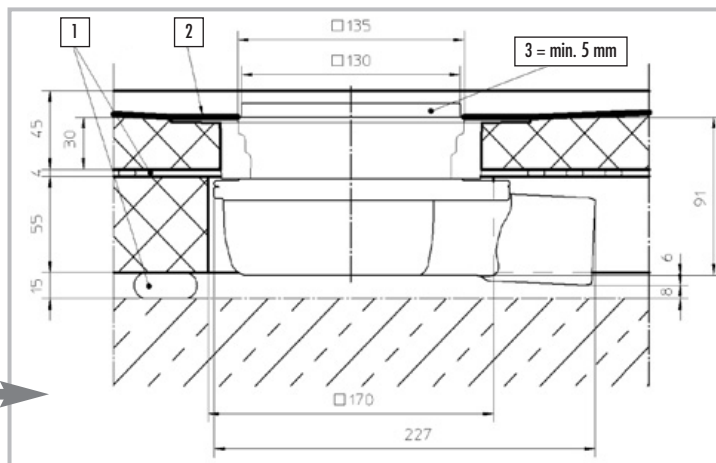
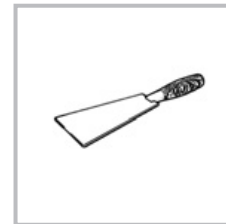
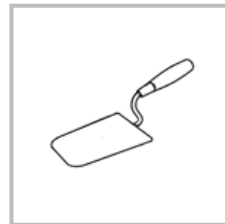
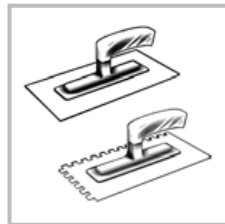
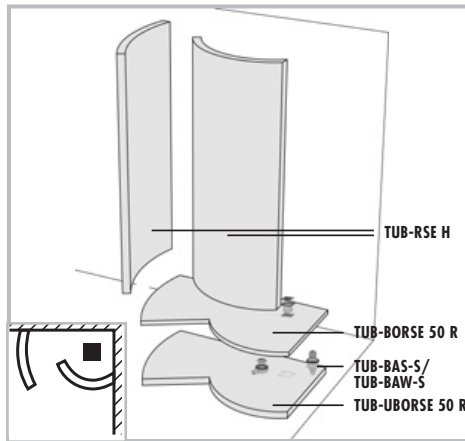
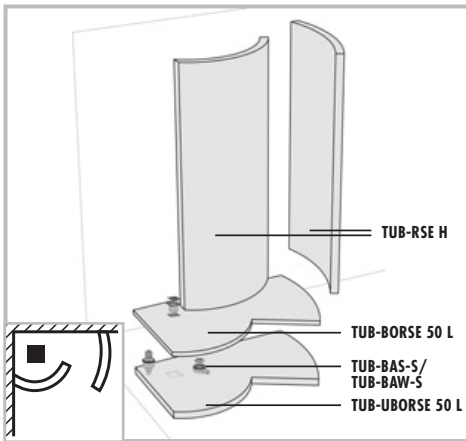
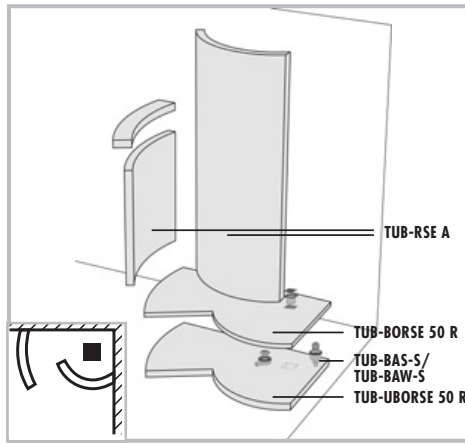
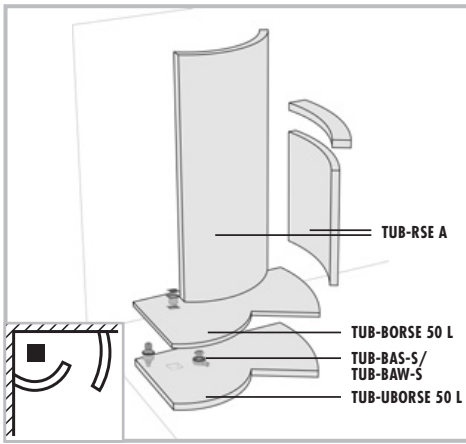

- D**
- 1 Kleberschicht
 - 2 Abdichtung
 - 3 Höhenanpassung
- GB**
- 1 Adhesive layer
 - 2 Seal
 - 3 Height adjustment
- F**
- 1 Couche de colle
 - 2 Étanchéité
 - 3 Adaptation en hauteur
- NL**
- 1 Lijmlaag
 - 2 Afdichting
 - 3 Hoogteaanpassing

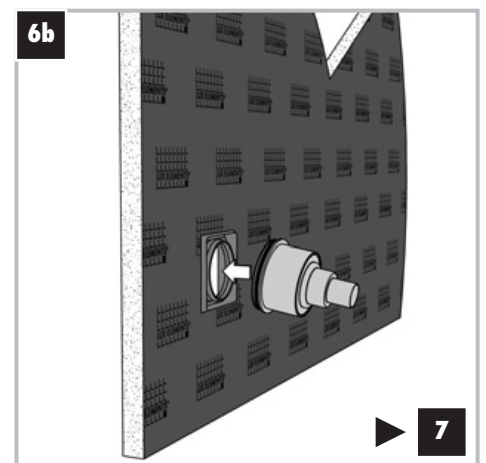
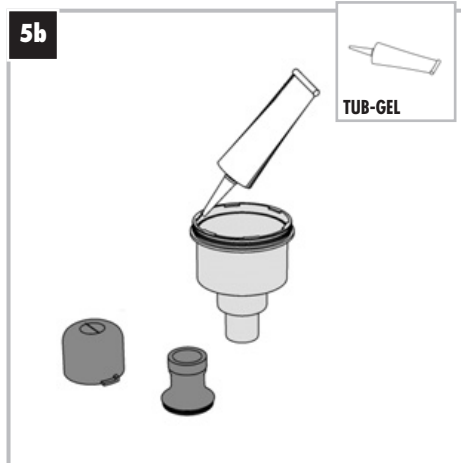
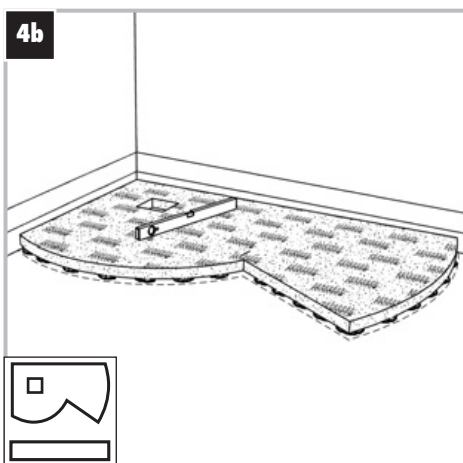
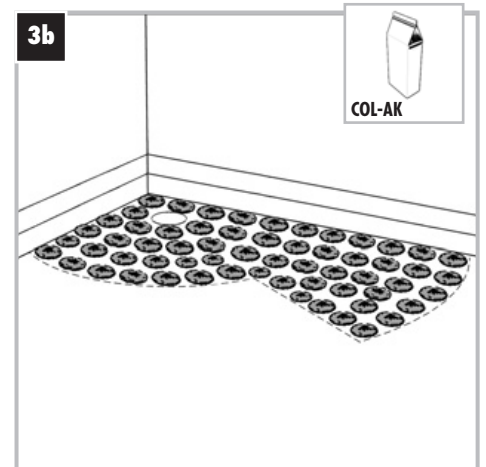
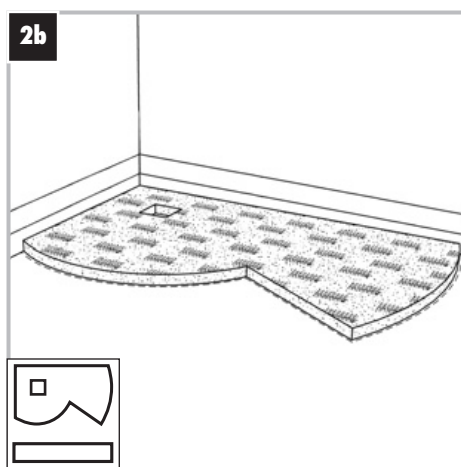
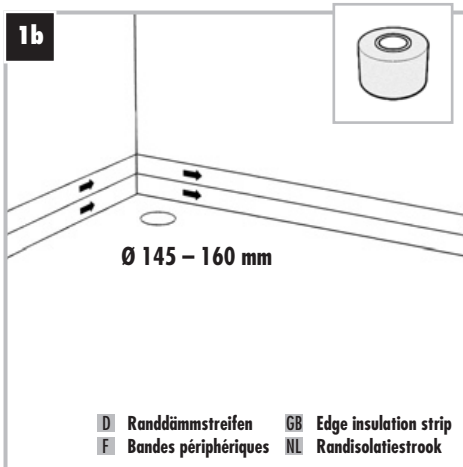
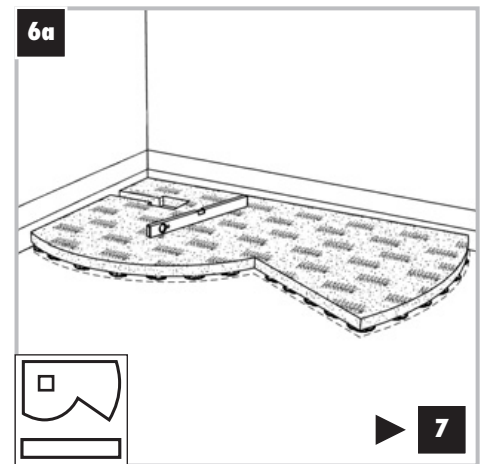
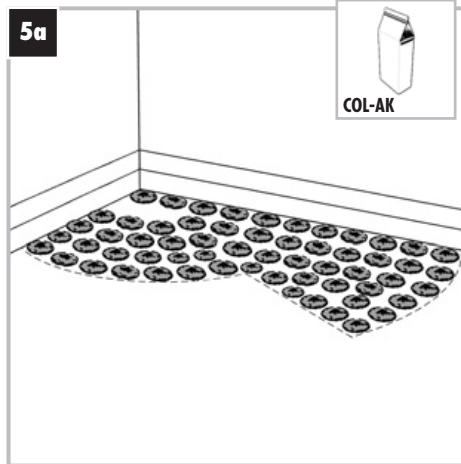
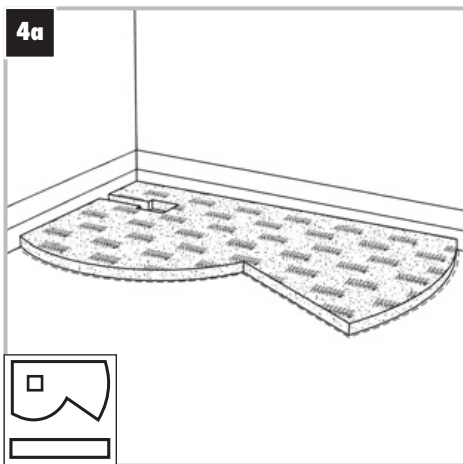
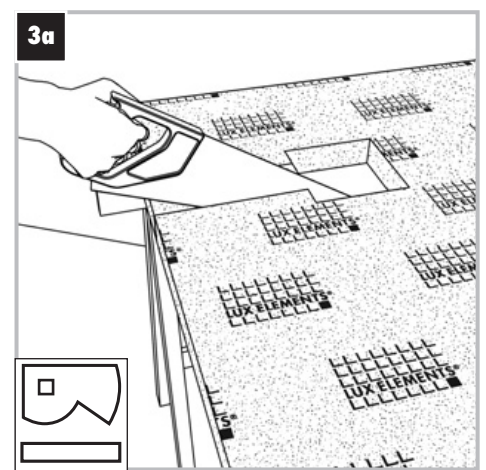
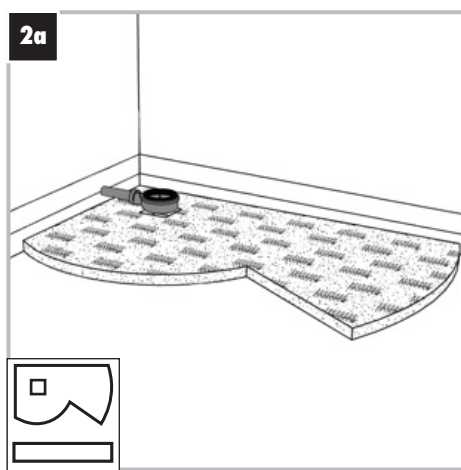
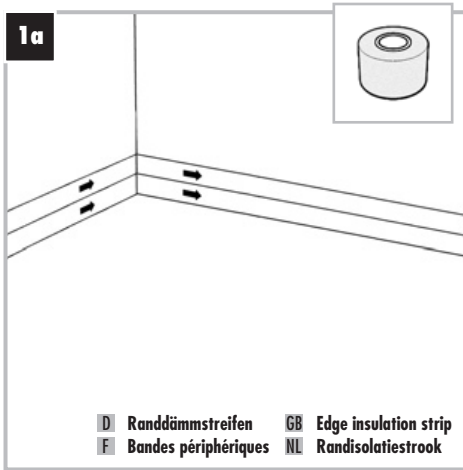

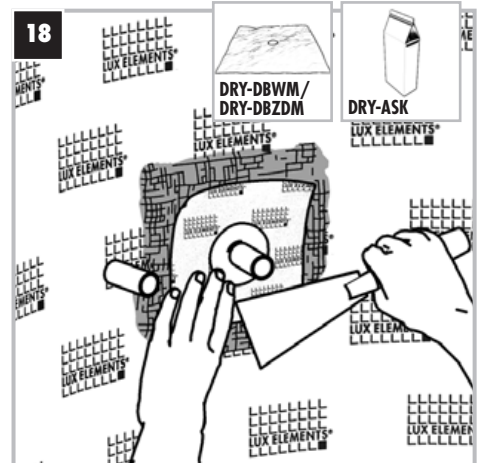
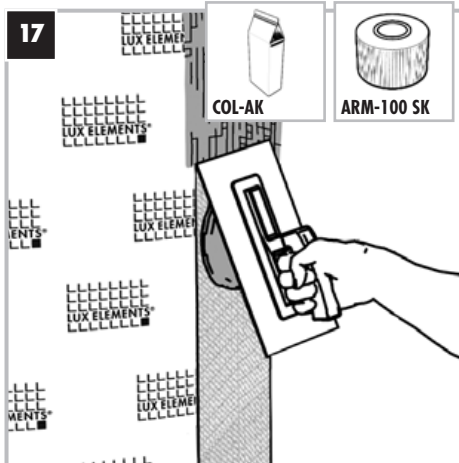
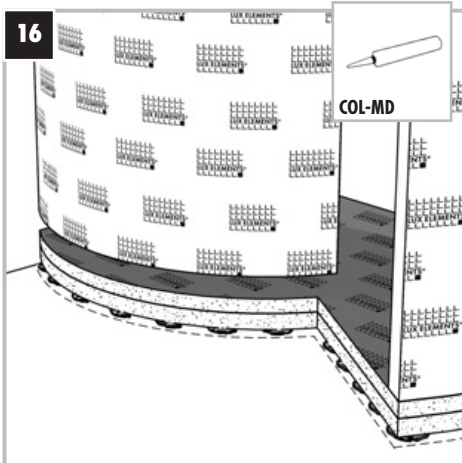
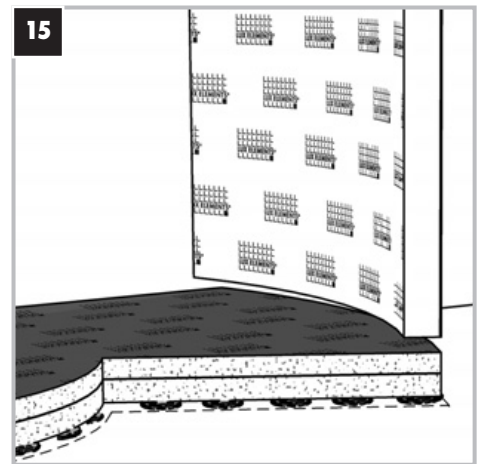
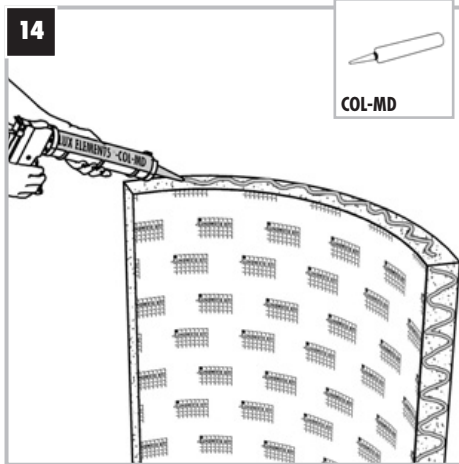
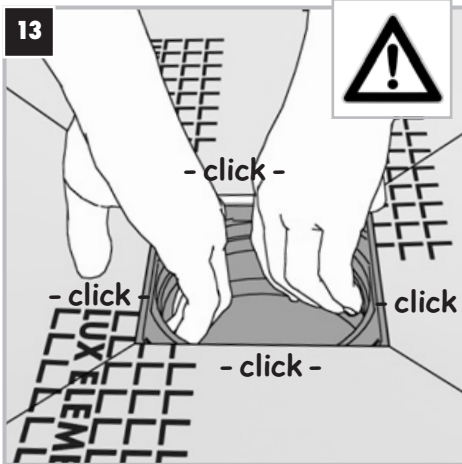
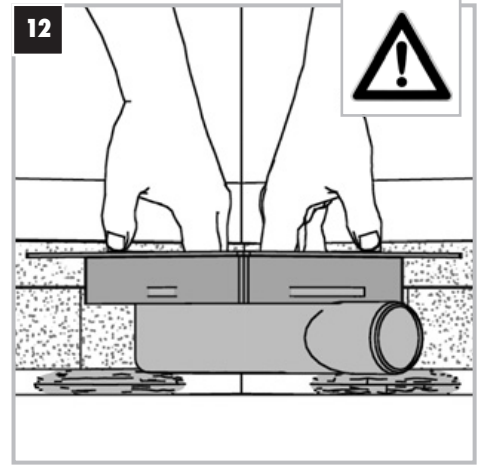
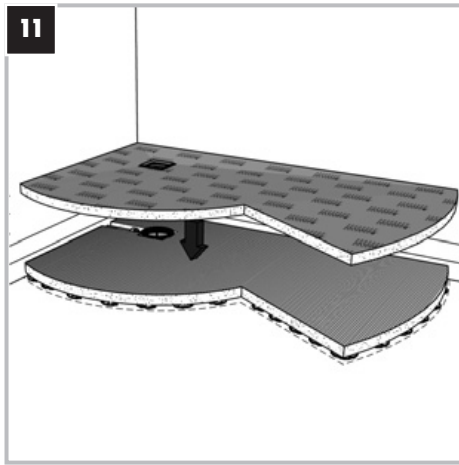
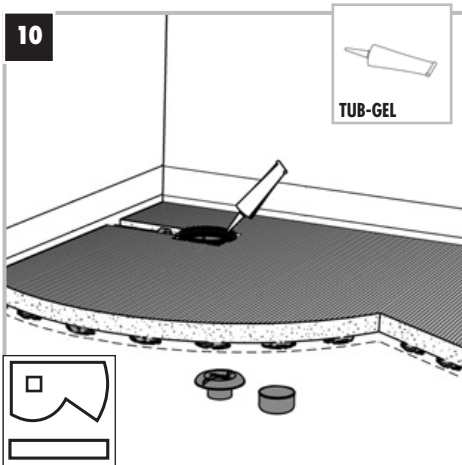
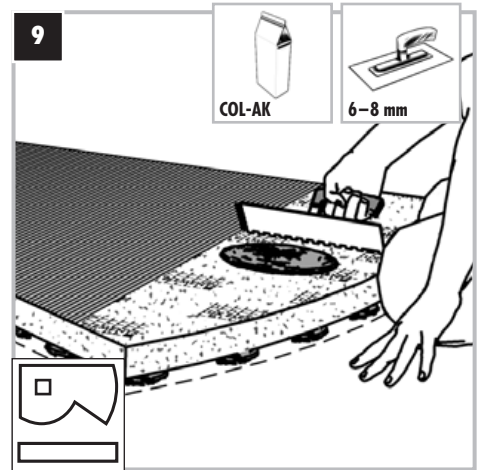
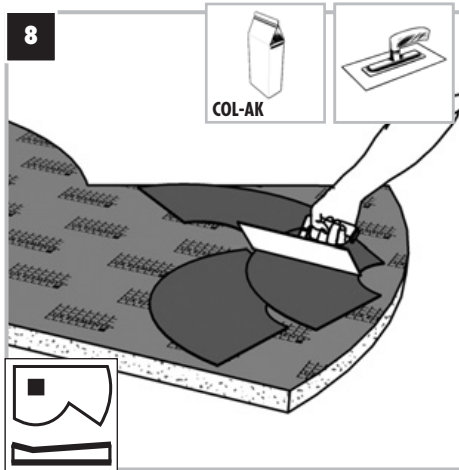
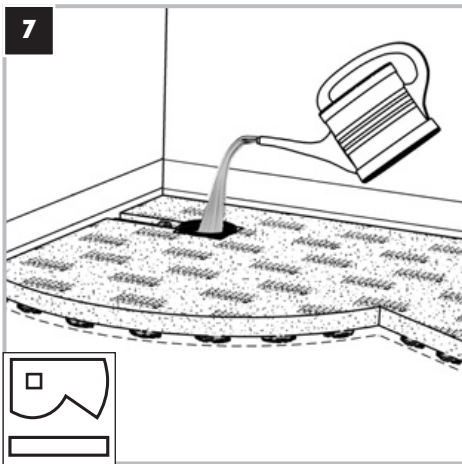

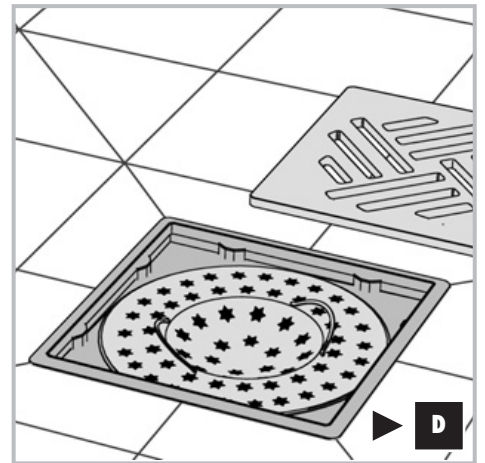
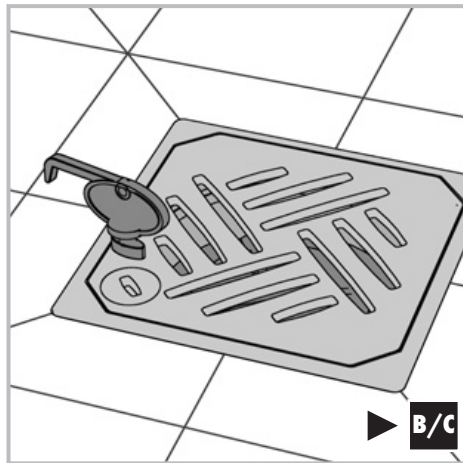
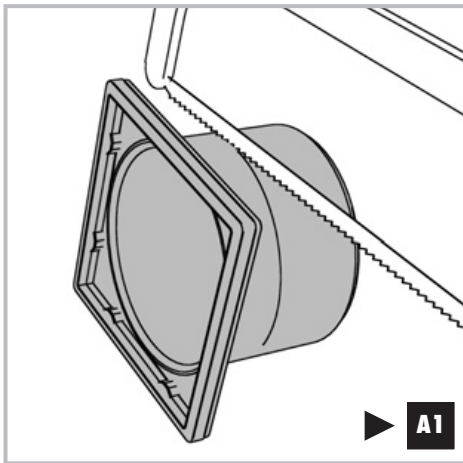
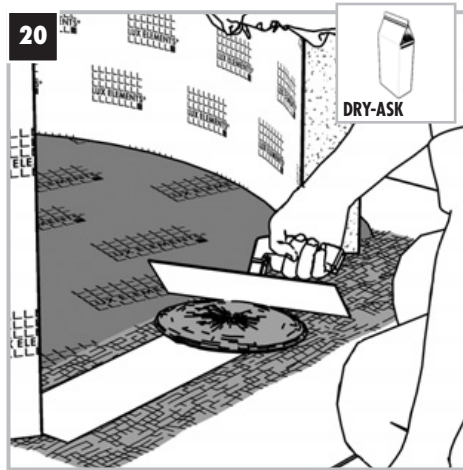
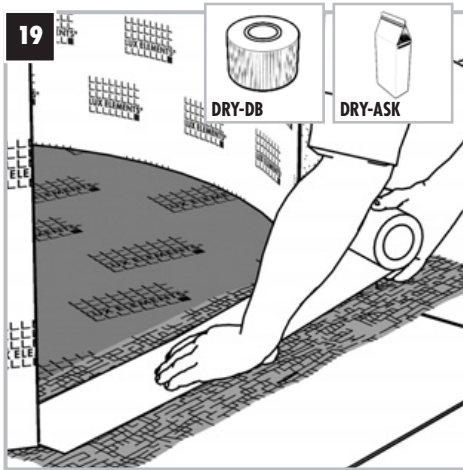

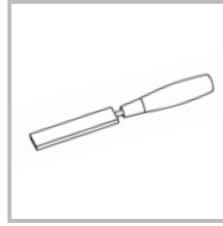
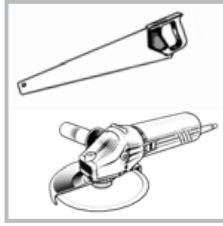
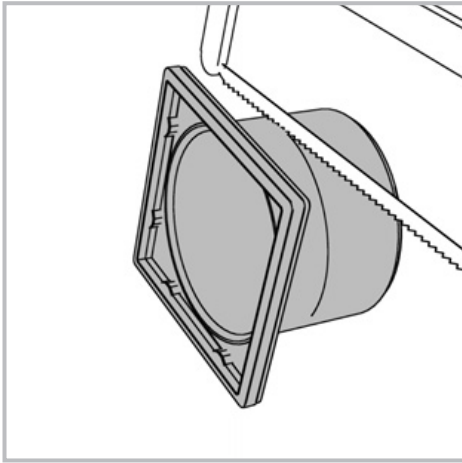

COL-FLEX



SILIKON

