

**LUX ELEMENTS – Individual concepts**  
Customised and special products





## Welcome to LUX ELEMENTS

True to our motto, 'Solutions for modern building design', our medium-sized family business based in Leverkusen, Germany, has been producing hard foam support elements for moist and wet areas for more than three decades. Founded back in 1945 as a tiling company, we have based our development of this modern building material on the practical experience we have gained processing tiles every day.

Our range of products extends from construction panels and standardised system building kits to constructions for wellness and bathing environments. Now you can find LUX ELEMENTS products all over the world: in the USA, China and throughout Europe. International, long-standing satisfied customers and partners from the tiling, sanitary and spa sectors can vouch for the quality of our products.

Cover photo:  
Hamam, Courtesy of Faena Hotel, Miami Beach.  
Photographer Nik Koenig.  
Design and Implementation by Design for Leisure.

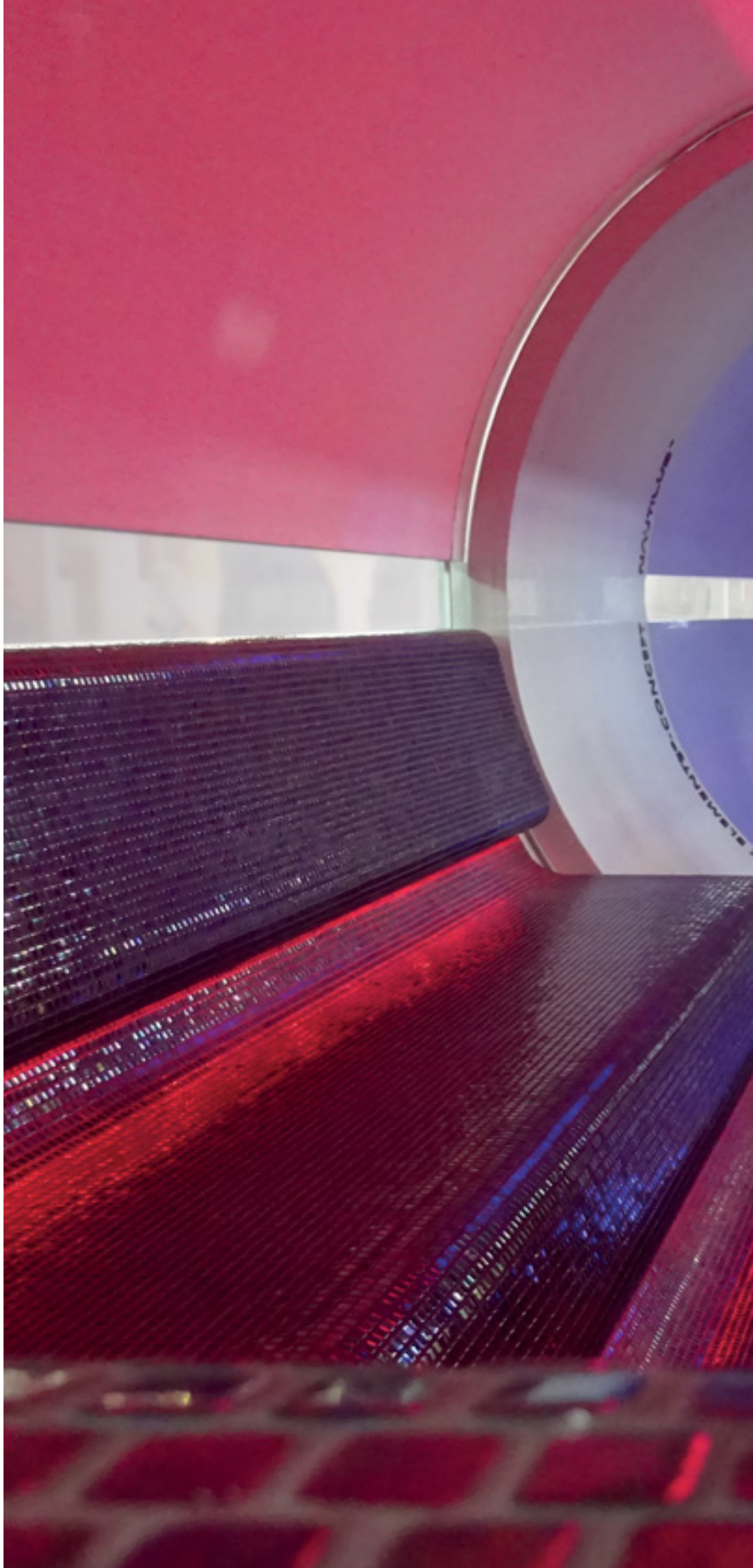



# LUX ELEMENTS – Individual concepts

## Content

### Solutions for modern building design

Planning spa projects – the right solution for every requirement	4
High material quality and environmentally-friendly production	6

### LUX ELEMENTS®-CONCEPT

Individual room constructions	8
Walls – floors – roofs	12
Seats and benches	14
Programme summary	16

### LUX ELEMENTS®-MODUL

Prefabricated room constructions	18
Programme summary	20

### LUX ELEMENTS®-RELAX

Individual relaxation and distraction	22
Relaxation loungers and massage tables	24
Bath tub construction kit and foot basins	26
Shower design variants	28
Accessories	30
Special formats	32
Programme summary	34

### LUX ELEMENTS®-DECO

Decorative elements	38
Programme summary	40

### LUX ELEMENTS®-FOAM

Foam parts	42
Technical solutions	44
LUX ELEMENTS as partner – from planning to finished item	48
We are able to do far more ...	54



## Planning spa projects

### **The right solution for every requirement**

Complete wellness facilities can be created from a single source with LUX ELEMENTS hard foam support elements. This gives them a particularly attractive uniform appearance.

Ranging from the walls, roofs and floors to seats, loungers, massage tables, bath tubs and footbaths as well as the shower unit or swimming pool cladding, nearly every single component can be constructed using hard foam support elements. Regardless of whether it is for private or public spaces..

LUX ELEMENTS gives you a choice between **standard** or **custom-made products**.

A multi-faceted surface design with ceramics or plasters in matching colours and patterns produces a perfectly uniform appearance in the end.

## ■ **Standard and custom-made products**

Combination of defined components  
or production according to customer specification

## ■ **Tried and tested building materials**

A patent was granted for the hard foam support element  
back in 1981

## ■ **Professional advice and support**

Support from an experienced international team

## ■ **Optional accessories**

From tested assembly material to technical accessories,  
e.g. steam inlet, light installations and heating systems

## ■ **Quick assembly even with large items**

Prefabricated elements made to fit together exactly can  
be assembled quickly and without long drying times

## ■ **Proven quality**

Certification according to DIN EN ISO 9001:2008  
as proof of quality management





# LUX ELEMENTS – Solutions for modern building design

## Hard foam support elements

### High material quality and environmentally-friendly production

The basic material for LUX ELEMENTS products is LUX ELEMENTS®-FOAM, a very high-quality, blue coloured, expanded polystyrene hard foam that is produced using an **environmentally friendly technique** without foaming agents which are harmful to the climate. The moisture-resistant material is ideally suitable for use in spas and wellness facilities.

During further processing, the hard foam becomes a hard foam support element with a special mortar coating on both sides. For increased rigidity values a glass-fibre fabric is additionally embedded in the mortar coating.

### No chance for mould – biological behaviour

LUX ELEMENTS®-FOAM does not provide a breeding ground for micro-organisms. It does not rot or get mouldy. FOAM is neither harmful to the environment nor hazardous to water.

The safety of FOAM is made most obvious by the fact that the same raw-material is used to make food packaging. In its composition, the EPS FOAM fulfils the recommendation V polystyrene of the German Federal Health Office.

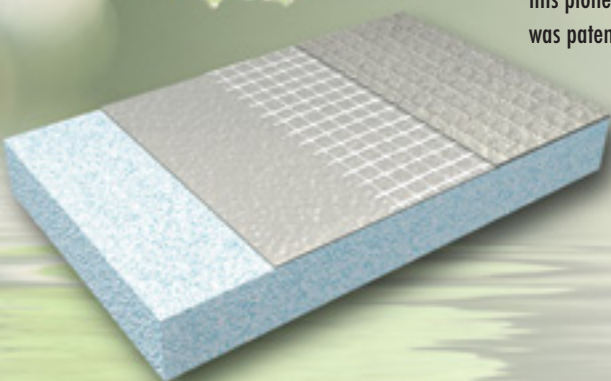

“The Original – LUX ELEMENTS®  
hard foam support element” –  
this pioneering invention in tiling  
was patented 1981 by Herbert Lux.

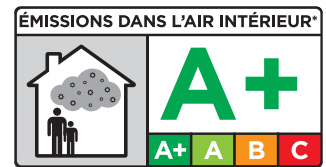

\*Information sur le niveau d'émission de substances volatiles dans l'air intérieur, présentant un risque de toxicité par inhalation, sur une échelle de classe allant de A+ (très faibles émissions) à C (fortes émissions)



ETA-13/0238  
LUX ELEMENTS®  
WATERTIGHT SOLUTION  
[www.luxelements.com](http://www.luxelements.com)  
0799-CPD-130 · Nr LEWS2013



# Proven material advantages

## The original can do!

Hard foam support elements from LUX ELEMENTS are characterised by particular material properties, which are of particular advantage for use in wet and humid conditions.



■ environmentally friendly



■ proven quality

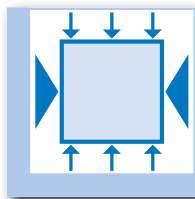

■ pressure-stable and rigid

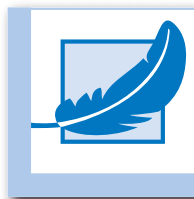

■ lightweight



■ waterresistant



■ fire-retarding

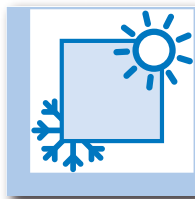

■ insulating

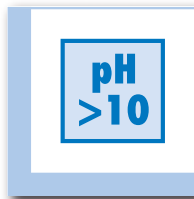

■ mould-resistant

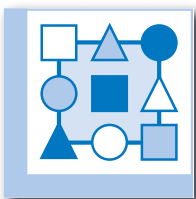

■ design variety



■ alternative surfaces



■ economical

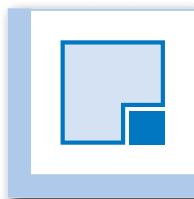

■ system-oriented

Since 1981, hard foam support elements from LUX ELEMENTS have been successful in practical use and have proved themselves there to this day. As a modern building material, the ORIGINAL must fulfil high requirements. This includes always meeting current technical standards and trends and being flexible. This is why we place great importance on continuous development of the ORIGINAL and the extension of a modern, system-oriented product range.

■ Would you like to learn more?  
Please see:  
[www.the-original-can-do.com](http://www.the-original-can-do.com)



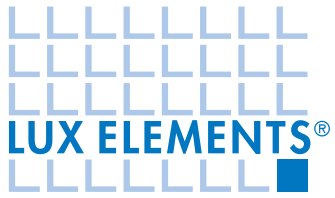

# LUX ELEMENTS – Individual concepts

Customised and special products







## LUX ELEMENTS®-CONCEPT

# Individual room constructions

Individually planned room constructions made of hard foam support material are used both as hot air areas, e.g. steam baths, and as cold areas.

You have the option of assembling your personal desired object from a wide range of pre-specified components or of planning it with complete freedom.

### ■ Idea and planning

You have an idea, a sketch or detailed plan.

We help you with the details and submit an offer.

### ■ Order and production

You place the order with us.

On the basis of your plans we prepare a technical drawing for approval.

You check and approve this.

We produce the individual components and test the assembly to check the fitting accuracy.

### ■ Assembly and arrangement

We deliver the products to the site, if necessary in segments.

We also deliver appropriate fitting accessories as part of the order.

You carry out the installation.

# LUX ELEMENTS – Individual concepts

## Customised and special products

### LUX ELEMENTS®-CONCEPT

## Mix and match ...

You can give free rein to your ideas at the planning stage. The modern, flexible production methods at LUX ELEMENTS make it possible to produce large items and a wide range of shapes.

Room constructions from the CONCEPT product group can be made up of these components, for example:

#### ■ Walls

also in combination with glass and metal constructions

#### ■ Floors

with optional substrate element and drainage technology. Optionally for point or linear drainage

#### ■ Roofs

in standard versions or individually planned

#### ■ Seats and benches

in standard versions or individually planned

#### ■ Accessories

such as glass door, aluminium door frame, door knob or handle, light strip and heating, steam inlet and installation panel and appropriate assembly material for the processing



Steam Room, Courtesy of Faena Hotel, Miami Beach. Photographer Nik Koenig. Design and Implementation by Design for Leisure.



# LUX ELEMENTS – Individual concepts

## Customised and special products

### LUX ELEMENTS®-CONCEPT

## Walls – floors – roofs

Hard foam support elements from LUX ELEMENTS enable you to create individual rooms or areas for wellness and spa facilities: for example, steam baths or even ice rooms. The material enables the forming of sophisticated structures such as window niches; **round shapes** such as dome roofs are also possible.

Cut into segments which fit together precisely and which can be assembled on site within a short time, even large objects can be constructed quickly. The method of construction for the connection of the individual components ensures particularly high stability (see page 16).

The final surface design of the hard foam support elements with selected plasters or ceramics produces an individual room or area, which radiates a feeling of comfort and harmony.

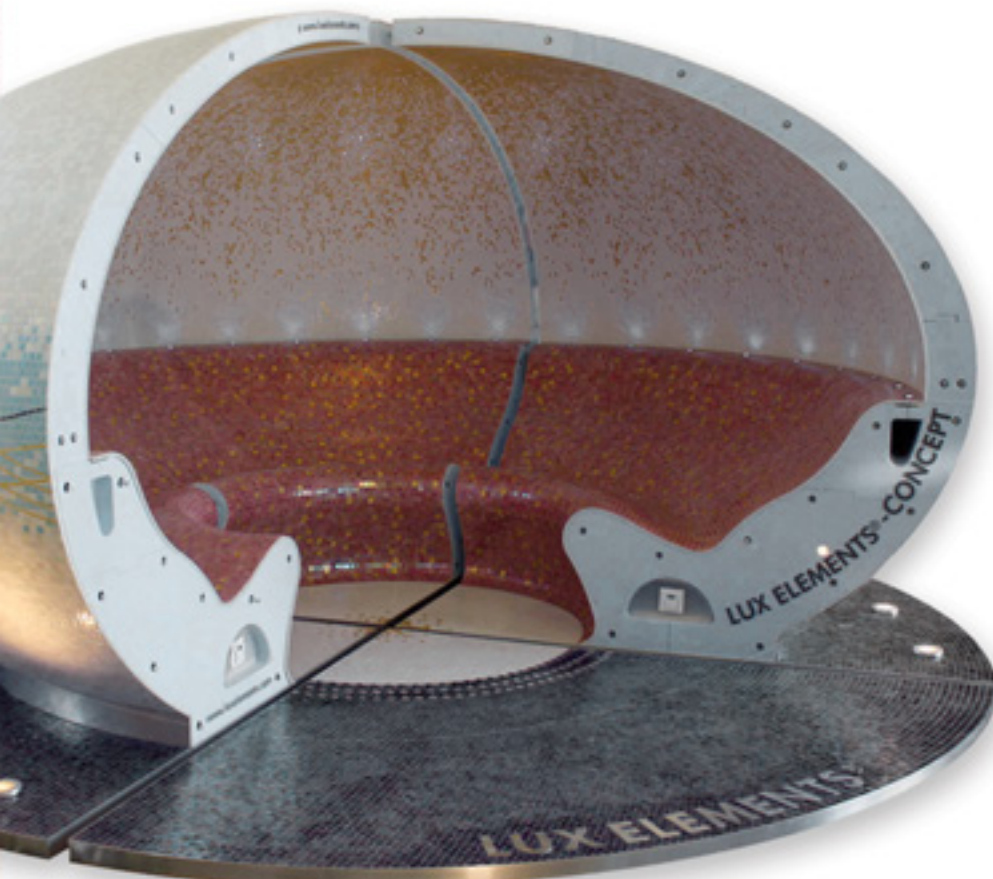
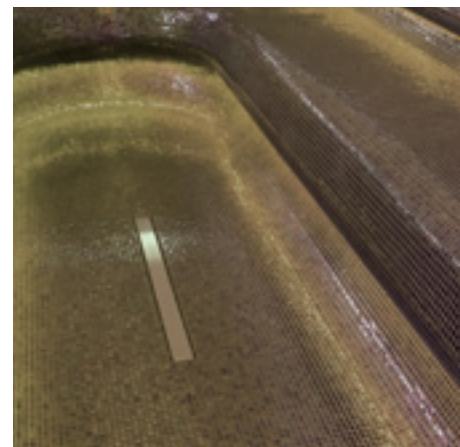
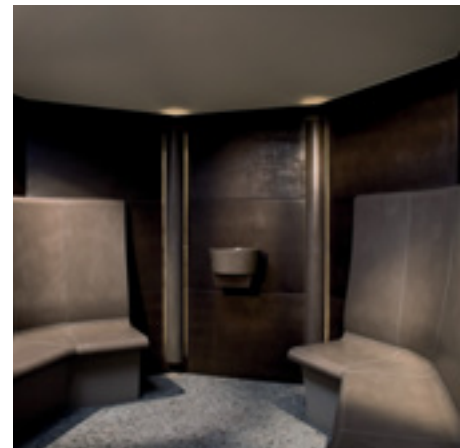



photo: Sommerhuber

**LUX ELEMENTS®-CONCEPT**

# Seats and benches

Comfortable seating is indispensable in hot air areas like steam baths. LUX ELEMENTS will supply you with seats and benches to match every room or area, even if it is full of nooks and crannies or round.

You can choose from **nine standard types of seating** with optional curved or end modules and arm rests or have **individually designed seats and benches** manufactured. All the products can be fitted with heating systems on request (see page 44).

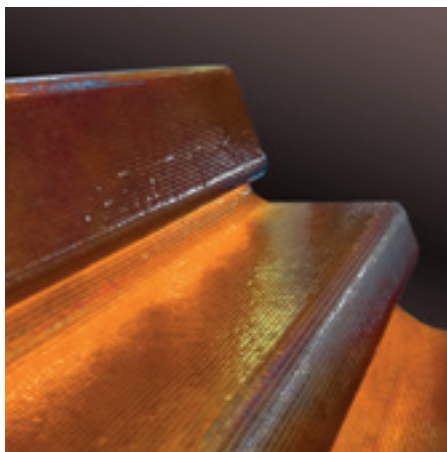
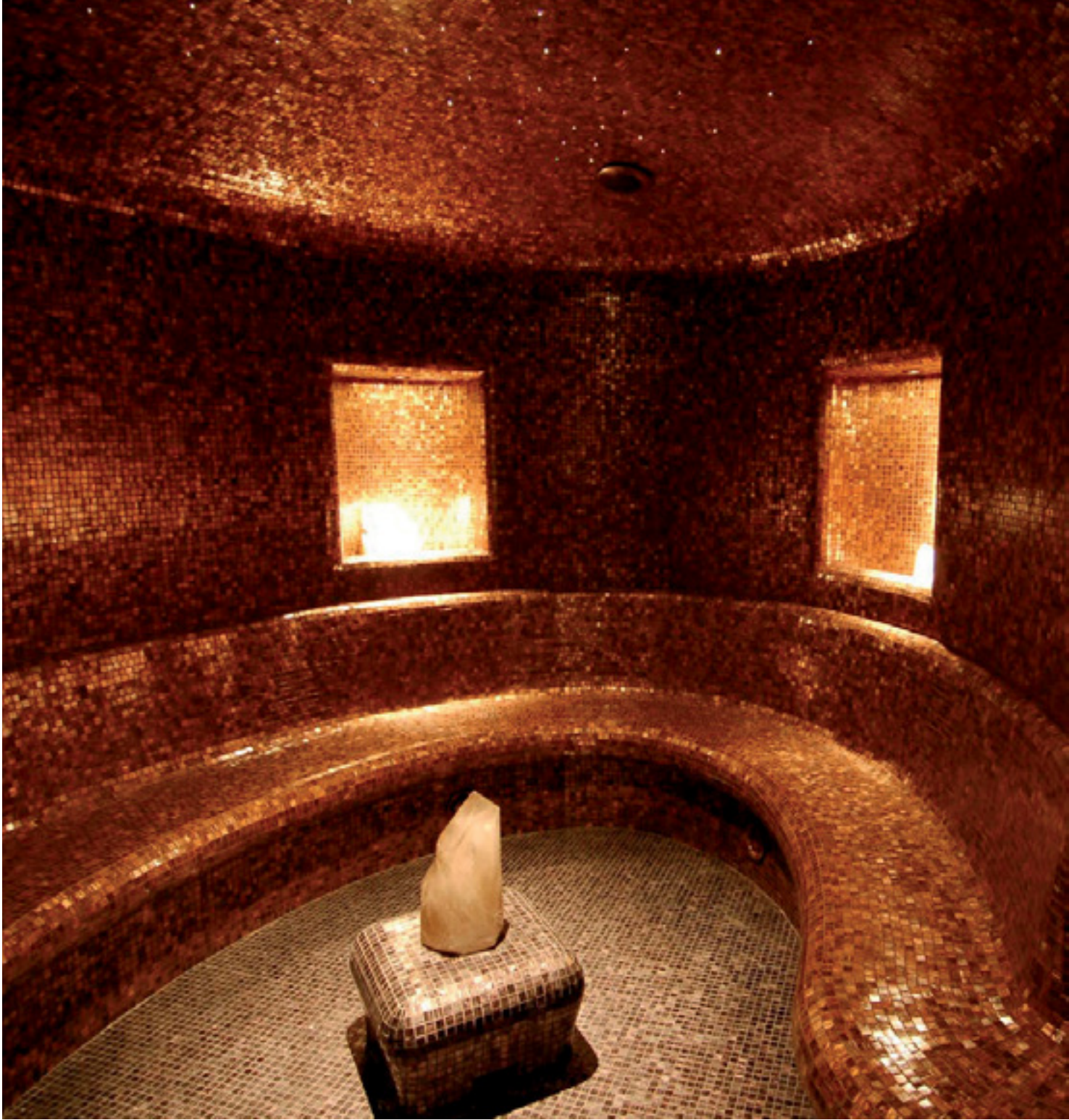

# Programme summary

## CONCEPT

### Roof

e.g. CONCEPT-DA-BARREL

### Wall construction as kit

### Frame

e.g. CONCEPT-DOOR-TZ B

### Glass door

### Seat

e.g. CONCEPT-BA-STEP

### Floor element

### Substrate element for floor element

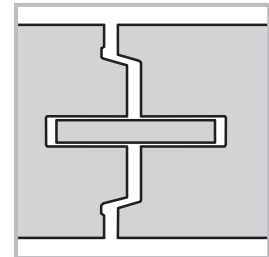
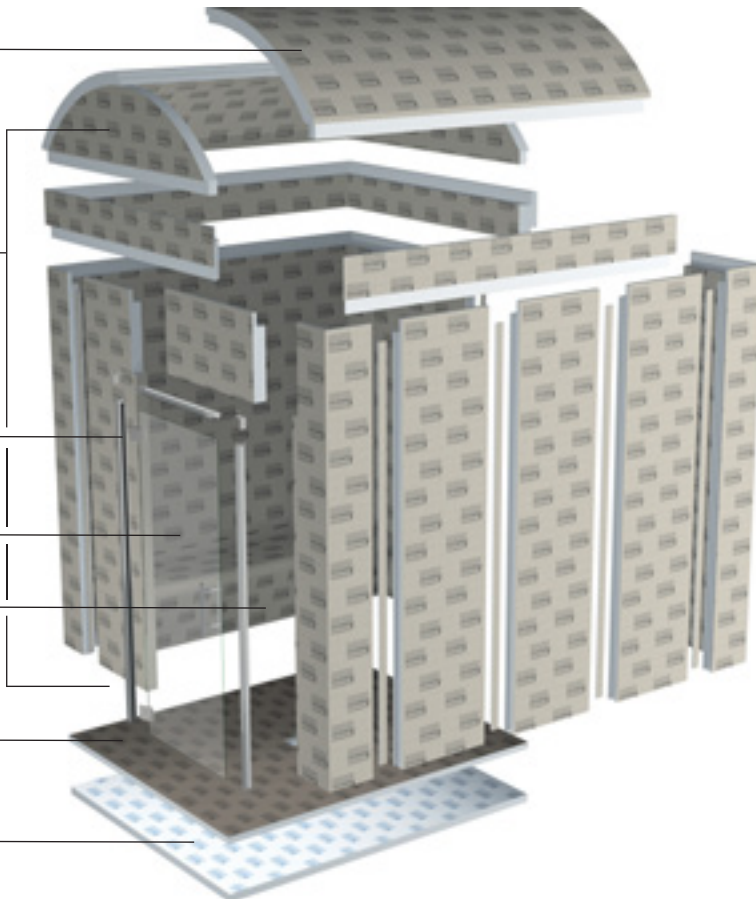

### Panel connection

The method of construction for the connection of the individual components ensures particularly high stability:

- Particularly stable panel connection thanks to tongue and groove principle
- Self-levelling panel connection thanks to V-groove
- Fast and simple assembly thanks to optimised fitting accuracy of the elements (gluing of individual wall elements up to a width of approx. 1200 mm in the factory)
- High production accuracy thanks to the use of state-of-the-art cutting technologies
- Stable fastening option for the door profile thanks to FIX-PRO-MAK over the entire panel width
- Flexible wall height: panel length up to 2500 mm, higher walls possible by using wall extension

## ■ Wall elements

Building kit for walls.

For the possibility to combine walls made of hard foam support material with a glass and metal construction, LUX ELEMENTS will supply a suitable design solution on enquiry.\*

■ CONCEPT-WA...

## ■ Floor elements

Floor elements with gradient and factory-fitted seal, alternatively for point or linear drainage. With fittings for drainage system\*\*.

■ CONCEPT-BO...

## ■ Substrate elements

For floor elements, 55 mm thick

■ CONCEPT-UBO...

## ■ Roofs

The following standard design variants are available:

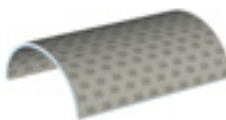

■ CONCEPT-DA-BARREL



■ CONCEPT-DA-CROSS

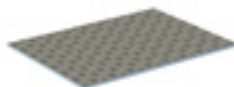
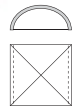

■ CONCEPT-DA-FLAT

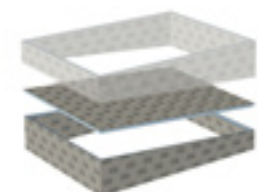

■ CONCEPT-DA-MONO

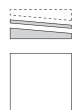

\*Enhancements are possible with optional accessories such as a steam inlet or installation panel (see page 47). \*\*We additionally offer suitable drainage.



## ■ Benches

straight line bench, available in running metres

Dimensions in mm

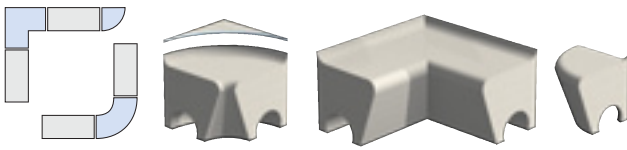

Rounded or mitred corner connection, bench end as rounded bench end or individually made to measure arm rest. (Example shows CONCEPT-BA-STEP)

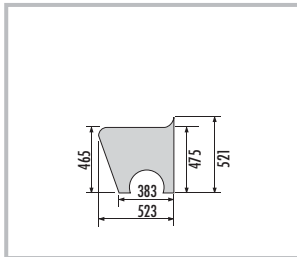

■ CONCEPT-BA-STEP

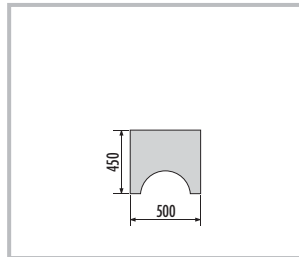

■ CONCEPT-BA-SOLO

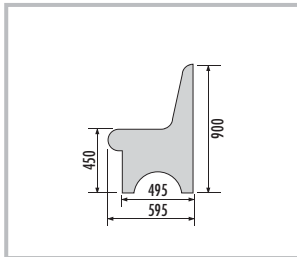

■ CONCEPT-BA-SIT

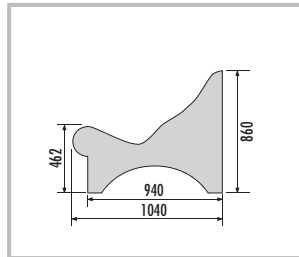

■ CONCEPT-BA-SLEEP

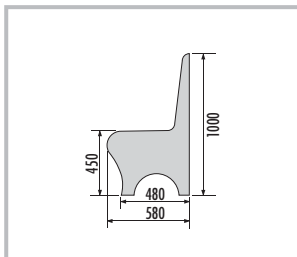

■ CONCEPT-BA-SLIM

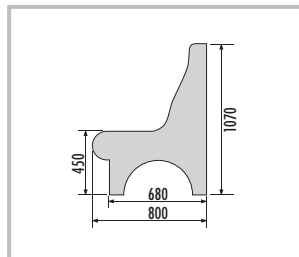

■ CONCEPT-BA-SOFT

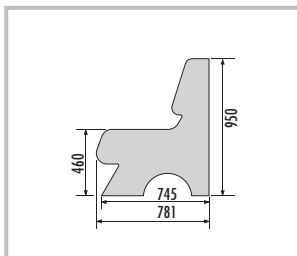

■ CONCEPT-BA-SPACE

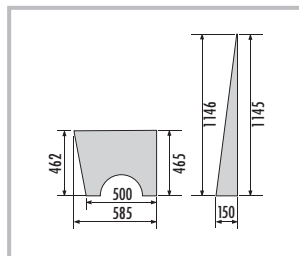

■ CONCEPT-BA-STAR

As an option, either a milling for the on-site installation of water heaters or an electrical heating set integrated at the factory with temperature sensor and temperature regulator can be ordered.

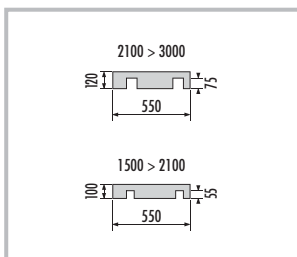

■ CONCEPT-BA-FLOAT

floating, bench and lounge with metal framework, bench form straight or with corner element. Indirect lighting and electrical heating set as surcharge.

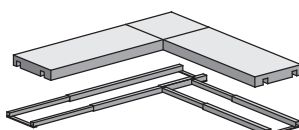

## ■ Accessories

Aluminum door frames made to measure as block profile or flat profile (also available in standard size). Surface polished similar to stainless steel, anodised, with locking mechanism and hinges for glass doors. Door knob similar to stainless steel, polished. Stainless steel handle bar brushed.

Glass door ESG 8 mm made to measure or standard size incl. drilling for handle bar or door knob.

Various Mounting kits for wall and floor constructions, depending on the size.



■ CONCEPT-DOOR-TZ B



■ CONCEPT-DOOR-TZ F

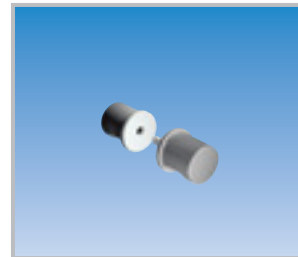

■ CONCEPT-DOOR-TK



■ CONCEPT-DOOR-GS



■ CONCEPT-DOOR-GT



■ CONCEPT-KIT-WA ...



■ CONCEPT-KIT-BO ...

### ■ NOTE:

For further information, please refer to our documents.

Data sheets, test certificates and processing instructions can be downloaded from [www.luxelements.com](http://www.luxelements.com) or visit our new YouTube-Channel on [www.youtube.com/user/luxelementscom](http://www.youtube.com/user/luxelementscom)





# LUX ELEMENTS – Individual concepts

## Customised and special products

### LUX ELEMENTS®-MODUL

# Prefabricated room constructions

Firmly defined room constructions **MODUL-CAB** made of hard foam support material, consisting of floor element, walls including door, seat and roof element.

The cabins are offered as building kits in various sizes with square, pentagonal or rectangular designs.

A building kit for cabins from the MODUL product group is comprised of the following components:

- **Roof** (roof form FLAT)
- **Wall construction** as kit
- **Seat** (bench form SOLO)
- **Glass door** (DOOR-GT-F-TK) with **door knob** (DOOR-TK)
- **Flat frame** (DOOR-TZ F-S)
- **Floor element** with floor drain support frame

Enhancements are possible with optional accessories such as a steam inlet or installation panel (see page 47).

Assembly accessories are offered as complete kits for all available sizes. We additionally offer suitable drainage.



# Programme summary

## MODUL

**Roof** (roof form FLAT)

**Wall construction**  
as kit\*

**Flat frame** (DOOR-TZ F-S)

**Glass door** (DOOR-GT-F-TK)

**Door knob** (DOOR-TK)

**Seat** (bench form SOLO)

**Floor element** with floor drain support frame\*\*

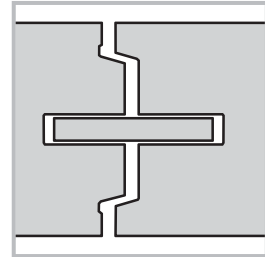
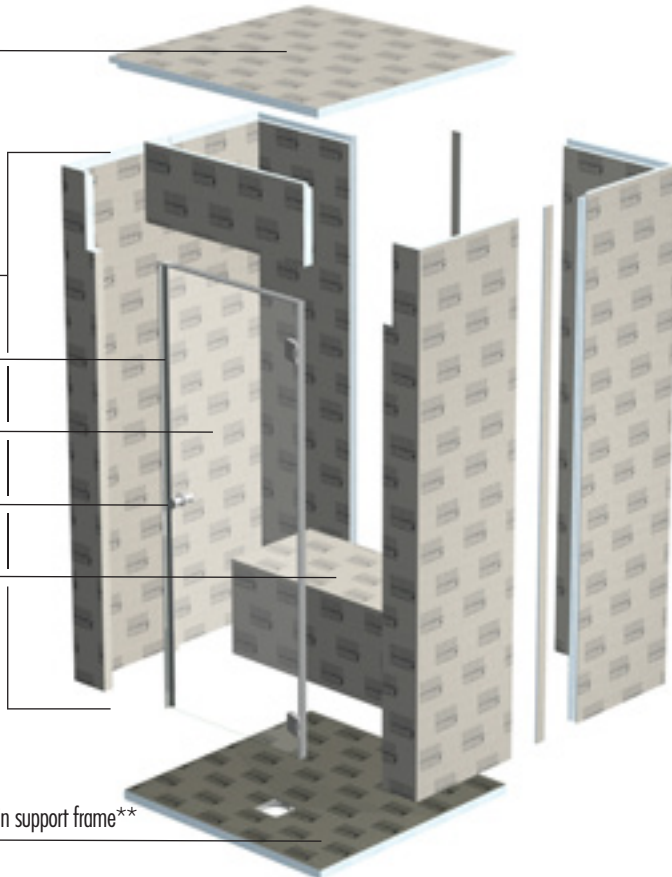

### Panel connection

The method of construction for the connection of the individual components ensures particularly high stability:

- Particularly stable panel connection thanks to tongue and groove principle
- Self-levelling panel connection thanks to V-groove
- Fast and simple assembly thanks to optimised fitting accuracy of the elements
- High production accuracy thanks to the use of state-of-the-art cutting technologies
- Stable fastening option for the door profile thanks to FIX-PRO-MAK over the entire panel width

\*Enhancements are possible with optional accessories such as a steam inlet or installation panel (see page 47).

\*\*We additionally offer suitable drainage.

## ■ Design variants

■ MODUL-CAB-F – pentagonal



■ MODUL-CAB-Q – quadratic

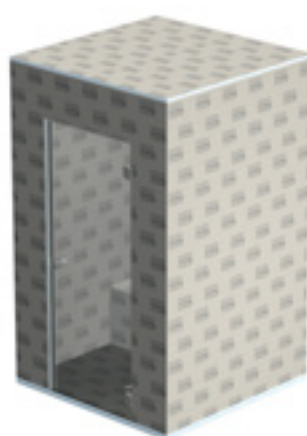

■ MODUL-CAB-R – rectangular

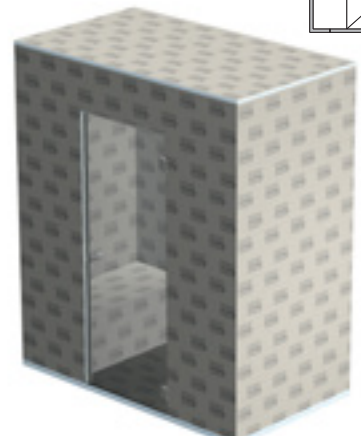
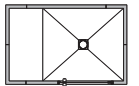

## ■ Sizes

Dimensions in mm

Steam room construction, wall thickness 50 mm, wall height 2390 mm, roof shape FLAT, DOOR-TZ F-S (flat frame) with DOOR-GT-F-TK (glass door) and DOOR-TK (door knob), with integrated and sealed floor drain support frame 135 x 135 mm, bench form SOLO (see page 17).

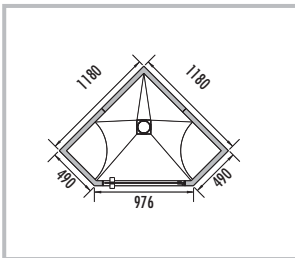

■ **MODUL-CAB-F 1180**  
pentagonal, 2 x bench form SOLO quadrant

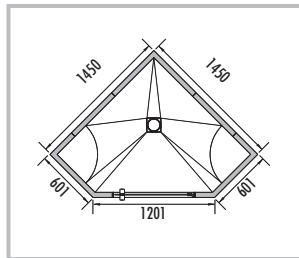

■ **MODUL-CAB-F 1450**  
pentagonal, 2 x bench form SOLO quadrant

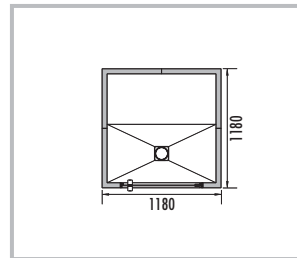

■ **MODUL-CAB-Q 1180**  
quadratic, 1 x bench form SOLO

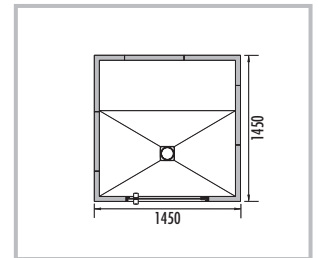

■ **MODUL-CAB-Q 1450**  
quadratic, 1 x bench form SOLO

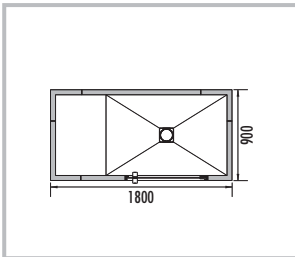

■ **MODUL-CAB-R 1800/900**  
rectangular, 1 x bench form SOLO

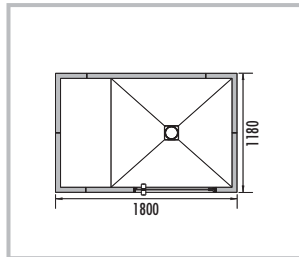

■ **MODUL-CAB-R 1800/1180**  
rectangular, 1 x bench form SOLO

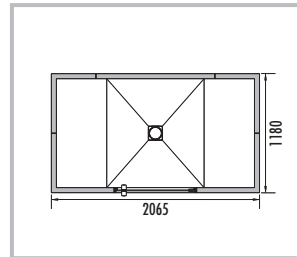

■ **MODUL-CAB-R 2065/1180**  
rectangular, 2 x bench form SOLO

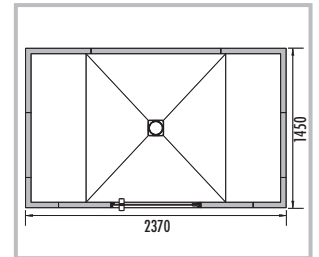

■ **MODUL-CAB-R 2370/1450**  
rectangular, 2 x bench form SOLO

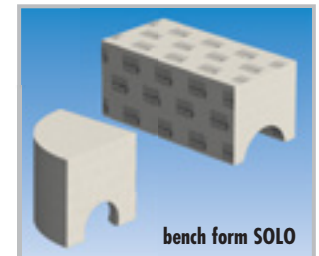
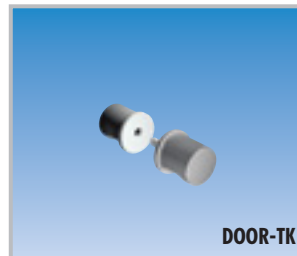

## ■ Assembly accessories



■ **MODUL-KIT-CAB 1**  
Mounting kit for walls, floors, roofs and benches for  
MODUL-CAB-Q 1180 and -Q 1450,  
MODUL-CAB-F 1180 and -F 1450,  
MODUL-CAB-R 1800/900, -R 1800/1180,  
and -R 2065/1180



■ **MODUL-KIT-CAB 2**  
Mounting kit for walls, floors, roofs and  
benches for  
MODUL-CAB-R 2370/1450

Assembly accessories  
are offered as complete kits for all available sizes.



### ■ NOTE:

For further information, please refer to our documents.  
Data sheets, test certificates and processing instructions can be down-  
loaded from [www.luxelements.com](http://www.luxelements.com) or visit our new YouTube-Channel  
on [www.youtube.com/user/luxelementscom](http://www.youtube.com/user/luxelementscom)



# LUX ELEMENTS – Individual concepts

## Customised and special products



### LUX ELEMENTS®-RELAX

## Individual relaxation and distraction

RELAX includes products made of hard foam support material for bathrooms and spa areas:

- Relaxation loungers (RELAX-RL) and
- Massage tables (RELAX-MT)
- Tileable bath tub building kits (RELAX-BW) and
- Footbaths with seat (RELAX-FB), each including drainage technology
- Building kits for shower design variants (RELAX-RD, RELAX-SD, RELAX-RSE, RELAX-JUNIOR)

Accessories such as

- Prefabricated niches (RELAX-NI),
- Bench seats for the shower area (RELAX-BA),
- Curbs (RELAX-CU) und
- Ramps (RELAX-RP) for shower bases with a step (Step-Up)

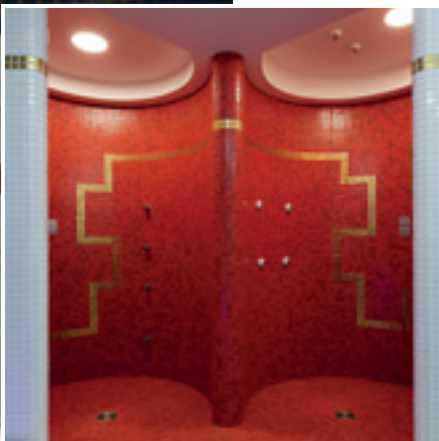

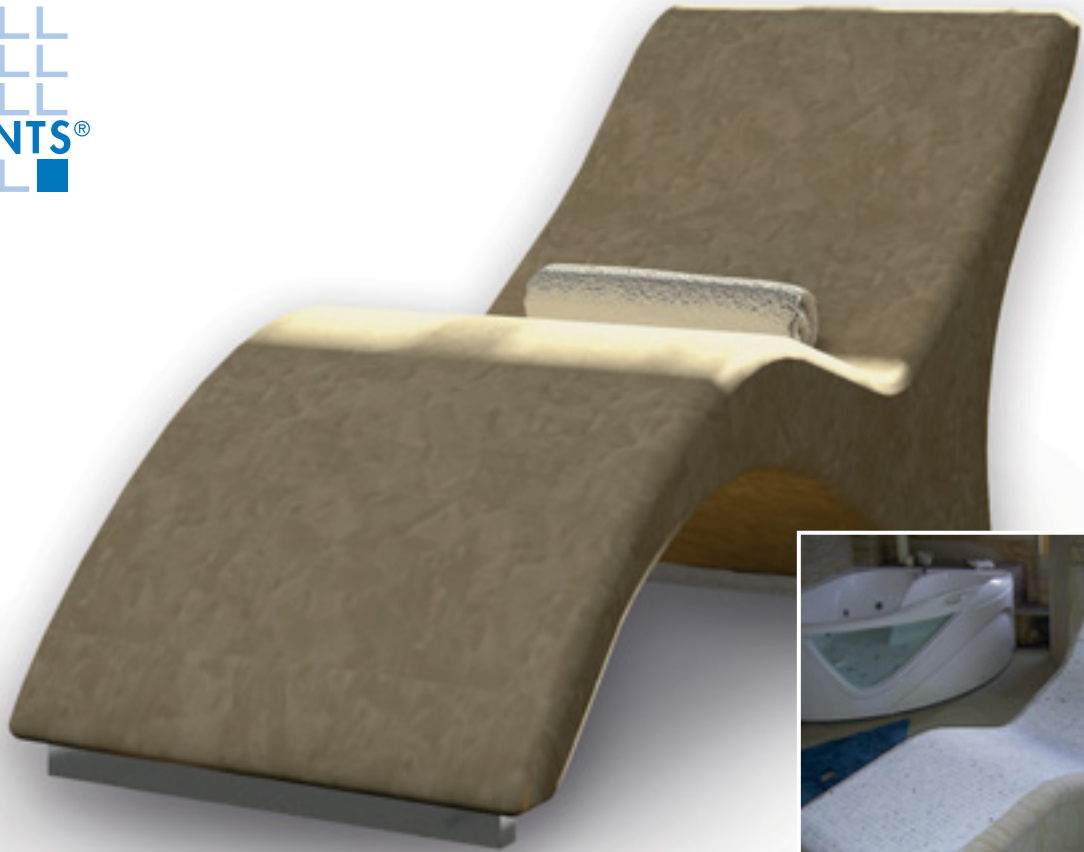

**LUX ELEMENTS®-RELAX-RL**

# Relaxing loungers

Loungers are a must in every wellness or spa area. They help people relax between active therapies in steam rooms and saunas etc.

LUX ELEMENTS uses hard foam support materials to make **loungers** which fit the body's shape perfectly and are therefore **extremely comfortable**. Unlike lounges with fabric coverings, the tiled surface is very **easy to clean** and so meets important hygiene criteria.

An additional advantage: electric or water heaters with fully adjustable controllers can be integrated into all the models.

The LUX ELEMENTS standard product range already includes five design options for loungers. In addition, individual models can be manufactured as single items or as a series (see page 32).







## LUX ELEMENTS – Individual concepts Customised and special products

### LUX ELEMENTS®-RELAX-MT

## Massage tables



Two massage tables are offered in the LUX ELEMENTS standard product range for enhancing the spa area. Both variants are equipped with a maintenance opening. This enables access to optional equipment such as heating, a water connection or drainage technology.

In addition, individual models can be manufactured as single items or as a series (see page 32).





**LUX ELEMENTS – Individual concepts**  
Customised and special products

**LUX ELEMENTS®-RELAX-BW**

# Tileable bath tub construction kits

RELAX-BW are tileable bath tub construction kits, with drain and overflow fittings and substrate element, in two different sizes.

Also available as additional fittings for the interior are two inlay elements in various designs.

In addition, individual models can be manufactured as single items or as a series (see page 32).



## LUX ELEMENTS®-RELAX-FB

# Foot basins

LUX ELEMENTS can make your Kneipp and foot bath a beautiful feature.

For example, **heated bench seats with integrated foot baths** in all kinds of designs are particularly appealing. Hard foam support material can also be used to make individually designed **Kneipp baths** to match the design of your rooms, areas and facilities perfectly.

Since hard foam support material is easy to work with, it is ideal for **installing equipment and fittings**.

The option of being able to create any surface design is a considerable advantage. High-quality ceramics in co-ordinating colours can produce exclusive original creations which will enhance any wellness environment..

The LUX ELEMENTS standard product range already includes an integrated solution consisting of prefabricated footbath with maintenance opening, including drainage technology, bench seat and substrate element.

In addition, individual models can be manufactured as single items or as a series (see page 32).

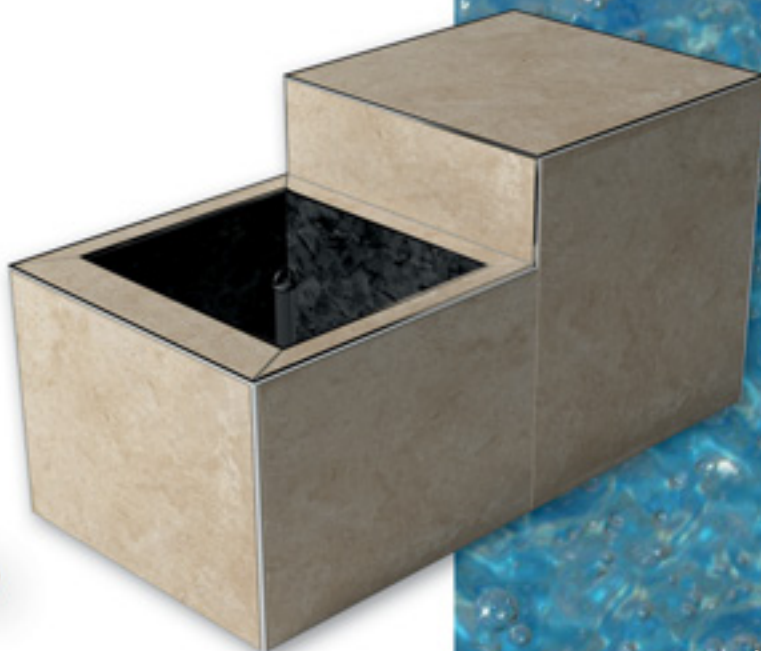



## **LUX ELEMENTS – Individual concepts** Customised and special products

### **LUX ELEMENTS®-RELAX**

# Shower design variants

A shower is a must in every wellness area, ideally a shower flush with the floor. Both its design and technology must fulfil particularly high requirements.

LUX ELEMENTS building kits for showers are robust and design-conscious. Be it a barrier-free single private shower or a complete shower facility, virtually any shape and size are possible. Round walls are popular as in curved or round showers.

Sealed, sloped shower bases with drain fittings as well as tested assembly materials can be ordered for any wall design. This applies to both standard range models and individually designed showers.

We will be happy to advise you on any issue concerning the installation of fittings and shower equipment.

#### **HINWEIS:**

For further information,  
please refer to our brochure  
"The Experience –  
Shower bases"

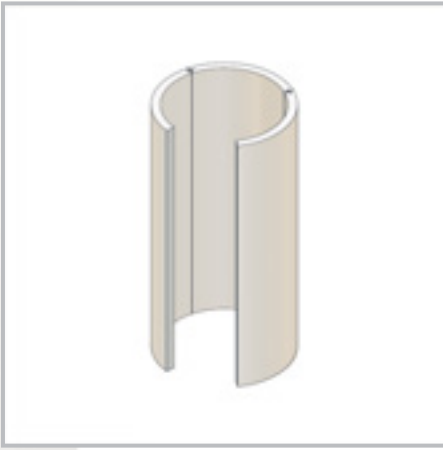

## RELAX-RD – round shower

RELAX-RD is a building kit for a round shower with the following components:

- Roof (2 design variants)
- Shower partition wall elements as kit in 3 segments
- Shower base element and substrate element for shower base element

Panel, rounded back for fixation of the shower rod and accessories and mounting kits suitable for RELAX-RD are provided. For further accessories, e.g. a concave trim for connection to the wall and finishing elements for the edges please see product group DECO (beginning page 40).

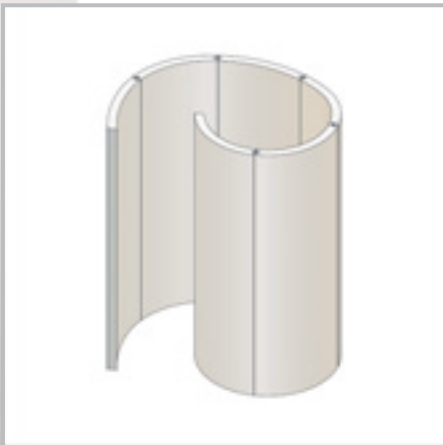

## RELAX-SD – curved shower

RELAX-SD is a building kit for a curved shower, left-curving or right-curving, with the following components:

- Roof (2 design variants)
- Shower partition wall elements as kit in 6 segments
- Shower base element and substrate element for shower base element

Panel, rounded back for fixation of the shower rod and accessories and mounting kits suitable for RELAX-SD are provided. For finishing elements for the edges please see product group DECO (beginning page 40).

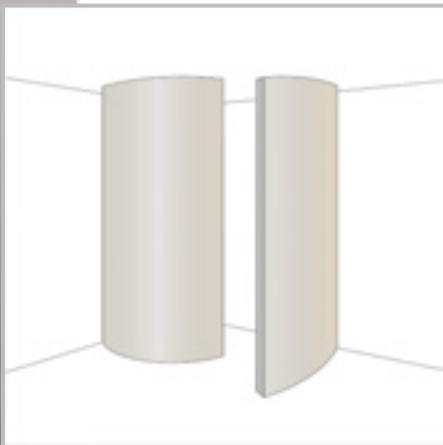

## RELAX-RSE – space-saving corner shower

RELAX-RSE is a building kit for a space-saving corner shower with two offset walls. This is available for left- or right-hand corner, either with two high walls or optionally with one high and one half-high wall with shelving. The kit contains the following components:

- 2 shower partition wall elements
- Shower base element and substrate element for shower base element

Mounting kits suitable for RELAX-RSE are provided. For further accessories, e.g. a concave trim for connection to the wall and finishing elements for the edges please see product group DECO (beginning page 40).

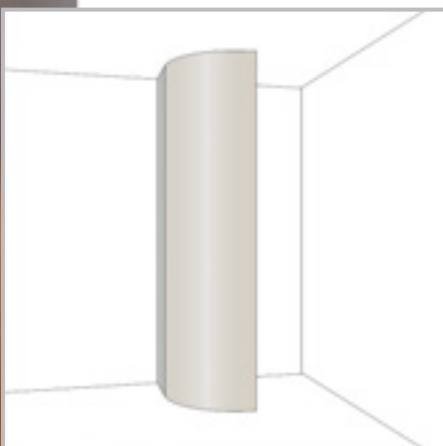

## RELAX-JUNIOR – corner shower

RELAX-Junior is a building kit for a corner shower in left- or right-hand corner, in two sizes complete with glass door. A mounted part allows the standard version to be increased in size. The kit contains the following components:

- Shower partition wall elements as kit in 2 segments and an extension element (optional)
- Glass door incl. hinge plates and stainless steel handle
- Shower base element and substrate element for shower base element

Mounting kits suitable for RELAXJUNIOR are provided. For a concave trim for connection to the wall please see product group DECO (beginning page 40).

# LUX ELEMENTS – Individual concepts

## Customised and special products

### LUX ELEMENTS®-RELAX

## Accessories

LUX ELEMENTS offers a large number of functional and decorative accessories for the bath and spa area.



### RELAX-NI – niches

Niches are an elegant and space-saving option for storage. Unlike protruding shelves, they are integrated into the wall. As a design element, niches make a wall surface visually more interesting. RELAX-NI are prefabricated niches in four formats: S-M-L-XL



### RELAX-BA – benches

Since bath tubs are being replaced more and more by flush with the floor showers, shower areas are becoming larger and offer space for an additional seat. RELAX-BA are prefabricated seats for the corner in a compact or 'floating' design as well as a wall-mounting bench seat in two widths.

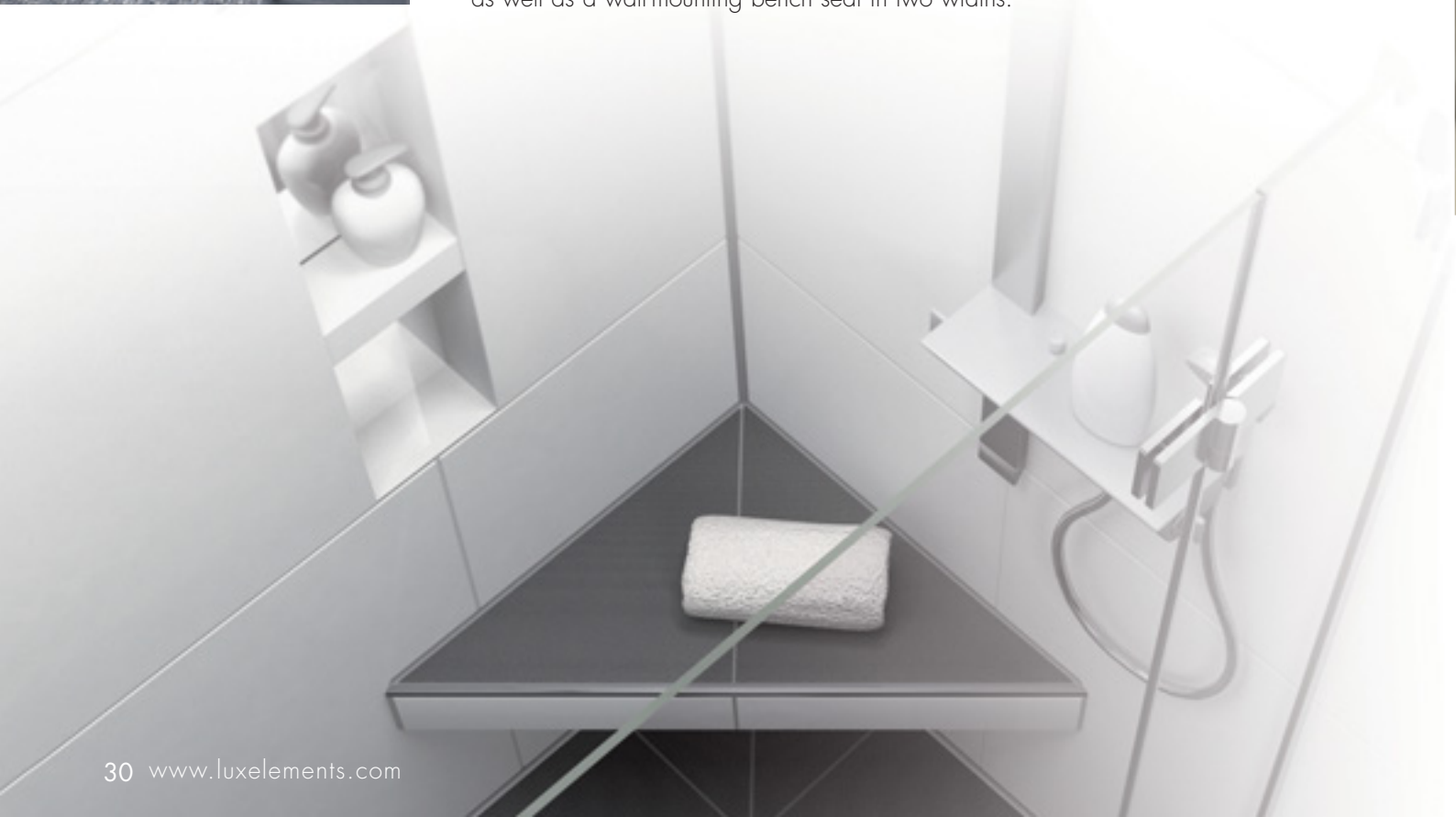



### **RELAX-CU – curbs**

RELAX-CU are prefabricated shower curbs in various lengths for use as water stops for shower bases with a step (Step-Up). The curbs can be adapted to fit any shower base dimensions by simply cutting to size.



### **RELAX-RP – ramps**

RELAX-RP are prefabricated ramps in two widths with different gradients and a length of 1828 mm for a barrier-free transition from bathroom floor to a shower base with a step (Step-Up). The ramps can be adapted to fit any shower base dimensions by simply cutting to size.



In addition, individual models can be manufactured as single items or as a series (see page 32).

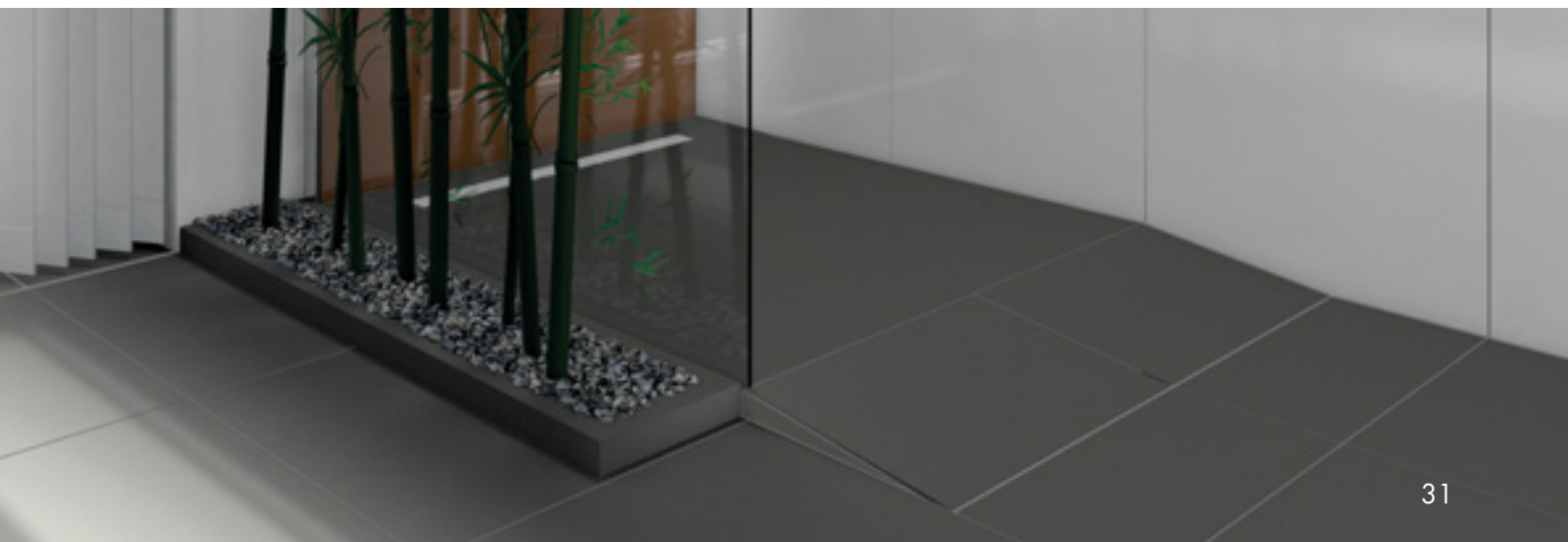

**LUX ELEMENTS®-RELAX-PLUS**

# Special formats

LUX ELEMENTS manufactures individual customised and special products for the RELAX product group listed under the designation „RELAX-PLUS“ from the area of:

- Relaxation loungers
- Massage tables
- Kneipp and foot baths
- Bath tub building kits
- Shower design building kits
- Niches
- Curbs and ramps
- Pools and underwater worlds

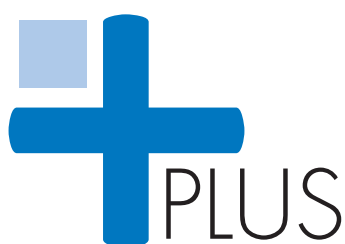

Sizes, shapes, thicknesses etc., that deviate from standard features can be inquired from LUX ELEMENTS. After successful verification of implementation possibility at LUX ELEMENTS an appropriate offer will be prepared. Once an order is placed, it will be manufactured and delivered accordingly.

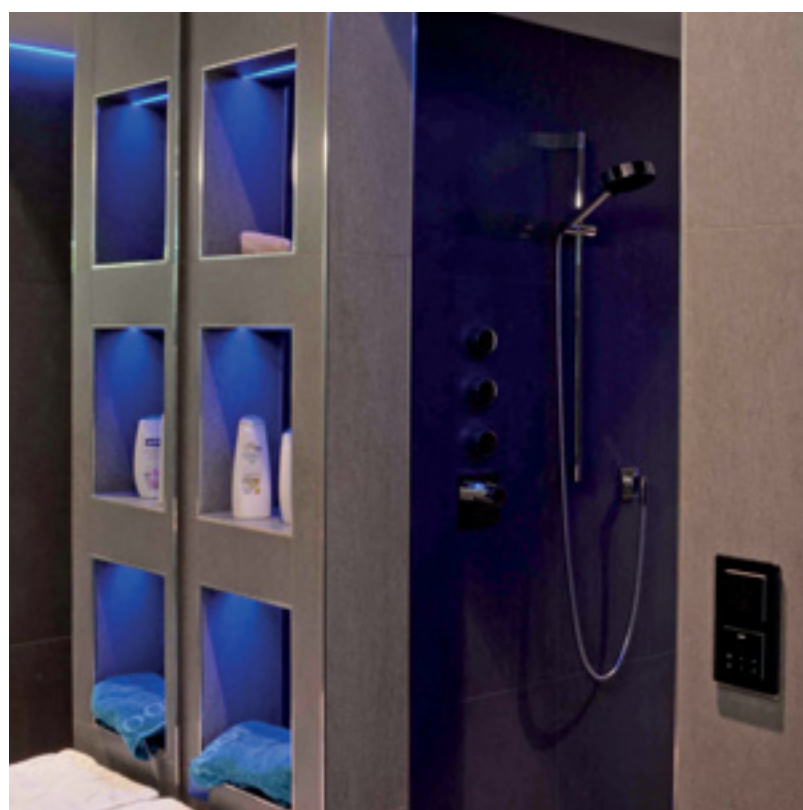

photo: Sommerhuber



# LUX ELEMENTS – Individual concepts

Customised and special products



photo: Sommerhuber

# Programme summary

## RELAX

dimensions in mm

### ■ RELAX-RL – relaxation loungers

Construction made of hard foam support material in five design variants, 700 mm wide, available with or without an electrical heating system.

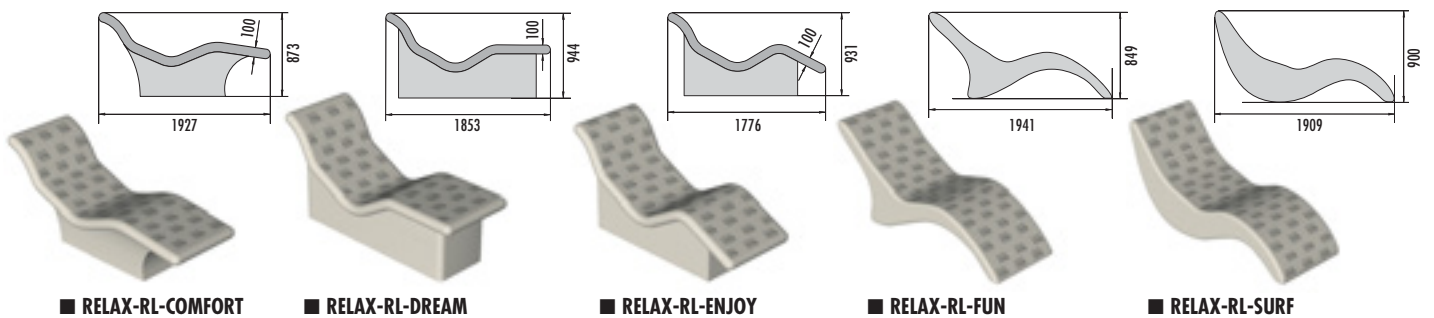

### ■ RELAX-MT – massage tables

Massage table with inspection opening, in two design variants, prefabricated from hard foam support material.

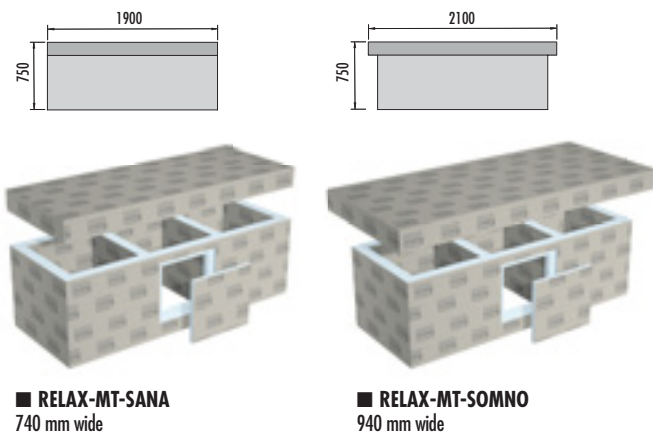

### ■ RELAX-FB – foot basins

Integrated solution prefabricated from hard foam support material.

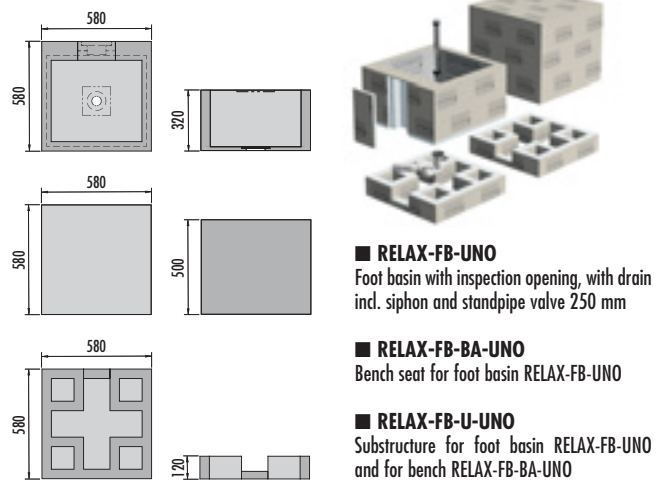

### ■ RELAX-BW – Bath tub construction kit

Construction made of hard foam support material, tileable, incl. drain and overflow fitting and base element

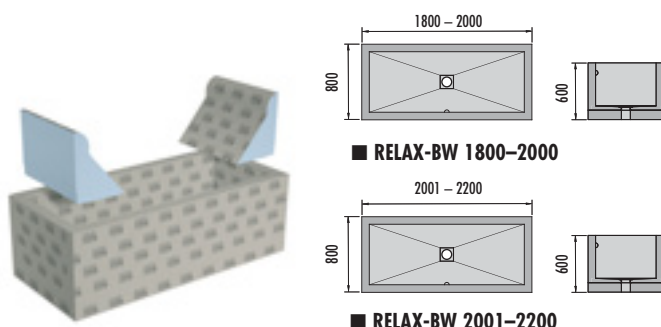

#### Accessories

- RELAX-BW ED  
Bath tub mounting part suitable for both tub sides, 'Triangle' design
- RELAX-BW EK  
Bath tub mounting part suitable for both tub sides, 'Headrest' design



■ RELAX-KIT BW  
Mounting kit for RELAX-BW

## RELAX-RD – round shower

Building kit made of hard foam support material

### RELAX-RD

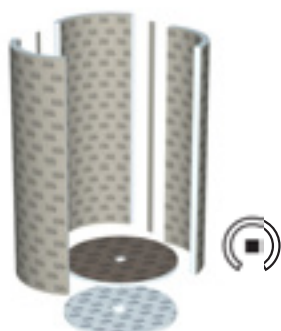

#### RELAX-RDW

Shower partition wall element, round, 2500 mm in height\*

#### RELAX-BORD 50

Shower base element, round, with integrated and sealed floor drain support\*\* in the centre

#### RELAX-UBORD 50

Substrate element for RELAX-BORD 50

### RELAX-RD – roofs

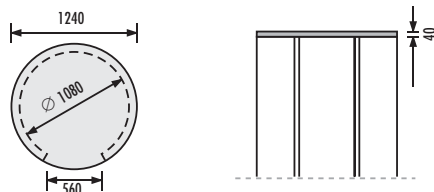

RELAX-DRD (Design FLAT)

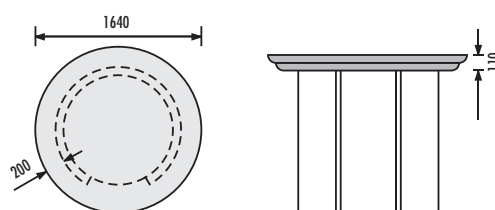

RELAX-DCRD (Design CLASSIC)

\*Instruction for installing the shower doors: When planning to install a shower door, a FIX-PRO-MAK hard plastic insert can be pre-assembled at the factory for fitting the door fastening on a custom-made basis. \*\*We additionally offer suitable drainage.

### Accessories



#### RELAX-KIT RDM

Mounting kit for RELAX-RD with RELAX-BORD 50



#### RELAX-KIT RDO

Mounting kit for RELAX-RD without base

## RELAX-SD – curved shower

Building kit made of hard foam support material, left-curving or right-curving.

### RELAX-SD

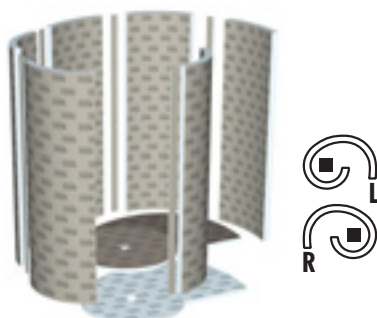

#### RELAX-SDW

Shower partition wall element, curved, 2500 mm in height

#### RELAX-BOSD 50

Shower base element, curved, with integrated and sealed floor drain support frame\*\*, square measure floor 1,71 m<sup>2</sup>, left- or right-curving available.

#### RELAX-UBOSD 50

Substrate element for RELAX-BOSD 50

### RELAX-SD – roofs

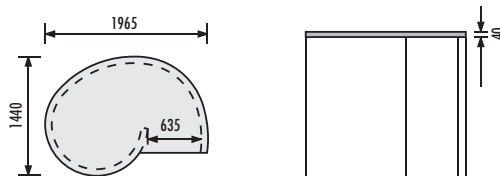

RELAX-DSD (Design FLAT)

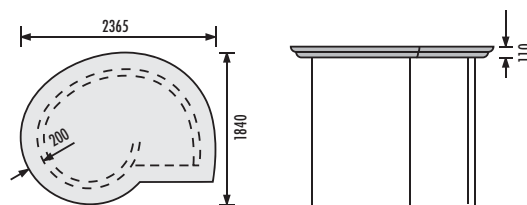

RELAX-DCSD (Design CLASSIC)

### Accessories

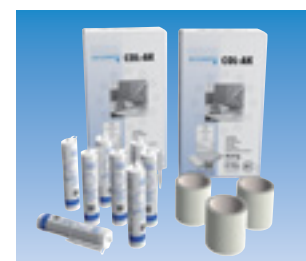

#### RELAX-KIT SDM

Mounting kit for RELAX-SD with BOSD 50

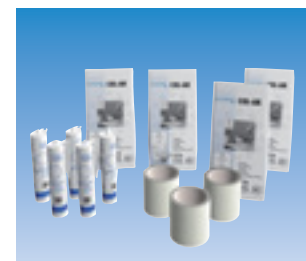

#### RELAX-KIT SDO

Mounting kit for RELAX-SD without base

### Accessories for round and curved showers

#### RELAX-PA

Panel, rounded back, with integrated FIX-PRO-MAK strips to fit RELAX-RDW and RELAX-RSW for the installation of shower rod and accessories. Alternatively, the FIX-IPA... installation panel is also suitable for mounting the fittings (see page 47).

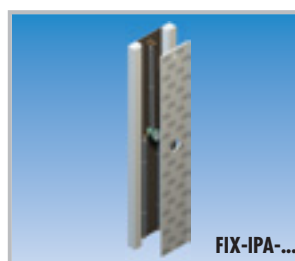

For more accessories, e.g. a concave trim for connection to the wall and finishing elements for the edges please see product group DECO (beginning page 40).

\*\*We additionally offer suitable drainage.

# Programme summary

## RELAX

dimensions in mm

### RELAX-RSE – space-saving corner shower

Building kit made of hard foam support material, left-curving or right-curving.

RELAX-RSE A

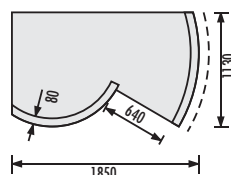
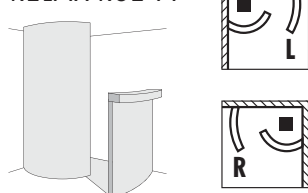

■ **RELAX-RSE A**  
2 shower partition wall elements, round,  
1 x 2500 mm in height,  
1 x 1200 mm in height plus shelf

■ **RELAX-RSE H**  
2 shower partition wall elements, round,  
each 2500 mm in height

RELAX-RSE H

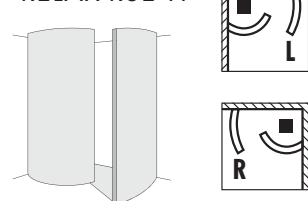

■ **RELAX-BORSE 50**  
Shower base element, with integrated and  
sealed floor drain support frame\*, left-curving  
or right-curving

■ **RELAX-UBORSE 50**  
Substrate element for TUB-BORSE 50

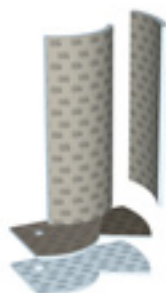
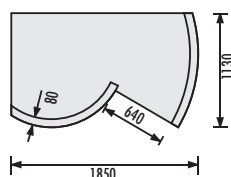

### Accessories – RELAX-RSE



■ **RELAX-KIT RSEM**  
Mounting kit for RELAX-RSE  
with RELAX-BORSE 50



■ **RELAX-KIT RSEO**  
Mounting kit for RELAX-RSE without base

### RELAX-JUNIOR – corner shower

Building kit made of hard foam support material, for left- or right-hand corner.

RELAX-JS

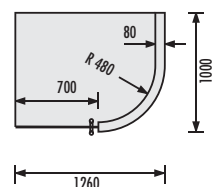
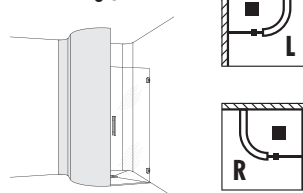

■ **RELAX-JS**  
Shower partition wall element,  
curved, 2500 mm in height,

■ **RELAX-JA (optional)**  
Shower partition wall extension element,  
2500 mm in height, incl. FIX-PRO-MAK strips  
for door fitting

RELAX-JS + JA

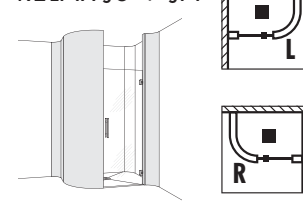

■ **RELAX-DOOR-BS**  
Glass door ESG 8 mm, incl. hinge plates and  
stainless steel handle, right and left hinged  
installation

■ **RELAX-BOJS**  
Shower base element, with integrated and  
sealed floor drain support frame\*, for left- or  
right-hand corner

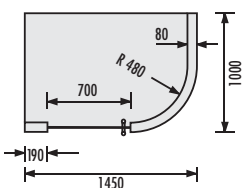

■ **RELAX-UBOJS**  
Substrate element for RELAX-BOJS

■ **RELAX-BOJSA**  
Shower base element extended, with integrated  
and sealed floor drain support frame\*, for left-  
or right-hand corner

■ **RELAX-UBOJSA**  
Substrate element for RELAX-BOJSA

### Accessories – RELAX-JUNIOR



■ **RELAX-KIT JM**  
Mounting kit for RELAX-JUNIOR  
with RELAX-BOJS or RELAX-BOJSA

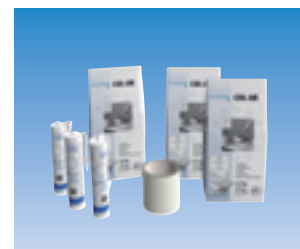

■ **RELAX-KIT JO**  
Mounting kit for RELAX-JUNIOR without base

# RELAX – Accessories

dimensions in mm

## RELAX-NI – niches

Prefabricated niches made of hard foam support material in four formats, 89 mm deep, interior depth 77 mm.

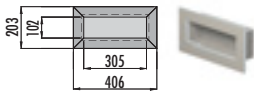

■ RELAX-NI-S

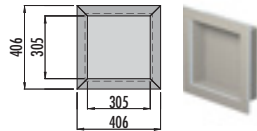

■ RELAX-NI-M

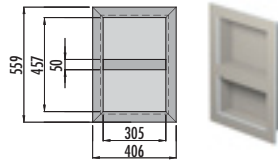

■ RELAX-NI-L  
including 1 loose shelf

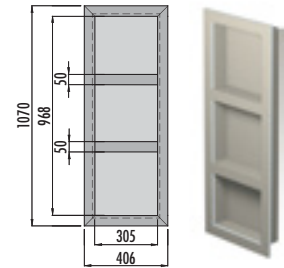

■ RELAX-NI-XL  
including 2 loose shelves

## RELAX-BA – benches

Prefabricated benches made of hard foam support material in three design variants.

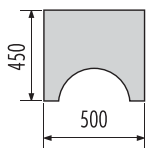

■ RELAX-BA-SOLO-G 900  
Bench form SOLO, straight, 900 mm long

■ RELAX-BA-SOLO-G 750  
Bench form SOLO, straight, 750 mm long

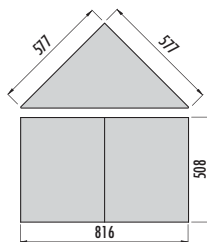

■ RELAX-BA-CO  
Bench form CORNER, triangular

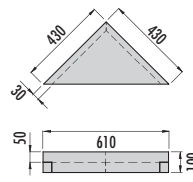

■ RELAX-BA-CO FLOAT S  
Bench form CORNER FLOAT S, floating,  
incl. mounting kit consisting of:  
6 pieces FIX-SB 80S35, 4 pieces FIX-SD 80  
and 1 cartridge COL-MK

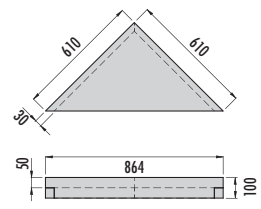

■ RELAX-BA-CO FLOAT L  
Bench form CORNER FLOAT L, floating,  
incl. mounting kit consisting of:  
6 pieces FIX-SB 80S35, 4 pieces FIX-SD 80  
and 1 cartridge COL-MK

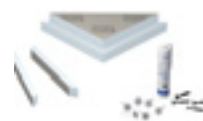
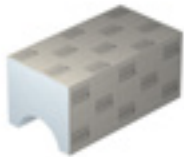

## RELAX-CU – curbs

Prefabricated curbs made of hard foam support material in 2 lengths.

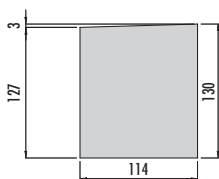

■ RELAX-CU-F-5  
1524 mm long

■ RELAX-CU-F-8  
2438 mm long

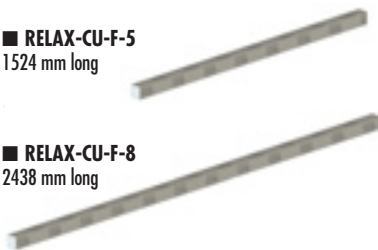

## RELAX-RP – ramps

Prefabricated ramps made of hard foam support material, 1828 mm long, in 2 widths with different gradients.

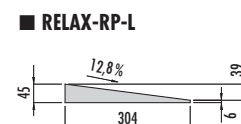
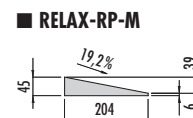

## Special formats – RELAX-PLUS

You can not find the right product? We also manufacture made-to-measure! Sizes, shapes, thicknesses etc., that do not correspond to the standard range can be enquired about separately at LUX ELEMENTS. After successful verification of the feasibility we will create a non binding offer. Once we receive your order, the order will be manufactured.



### NOTE:

For further information, please refer to our documents. Data sheets, test certificates and processing instructions can be downloaded from [www.luxelements.com](http://www.luxelements.com) or visit our new YouTube-Channel on [www.youtube.com/user/luxelementscom](http://www.youtube.com/user/luxelementscom)

# LUX ELEMENTS – Individual concepts

## Customised and special products

### LUX ELEMENTS®-DECO

# Decorative elements

It is often small details which have the most effect. Ornaments and accessories from LUX ELEMENTS lend your large items exclusivity.

Use beautiful and decorative **columns** as **accent features**. **Concave trims, curvature and finishing elements** round off the overall appearance in the truest sense of the word. You can choose from our standard product range or implement your own ideas (see page 41).

There are many ways of creating surfaces. You can choose from ceramics, usually small format mosaic tiles for round shapes, or decor plasters. A mix of materials can also be very attractive.

Be as imaginative as you like!



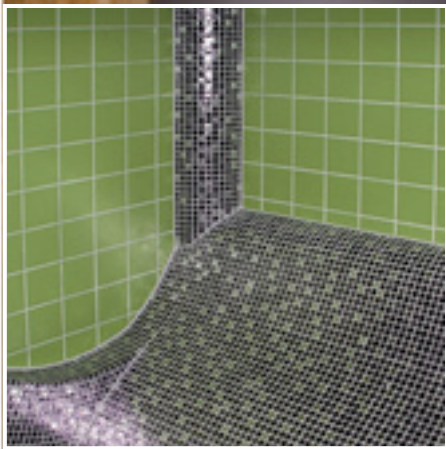

# Programme summary

## DECO

### ■ DECO-... – concave trims

dimensions in mm

Concave trims made of hard foam support material are fitted in corners for rounding off inwards e.g. in steam rooms, showers and room corners. The DECO-RD-HK concave trim is used as a round shower fitting part to the wall. In this way an acute-angled gap is covered.

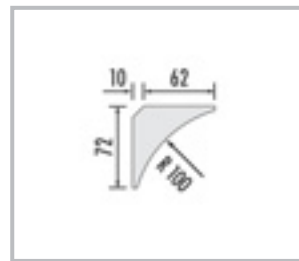
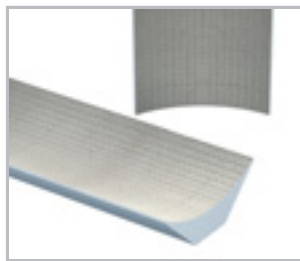
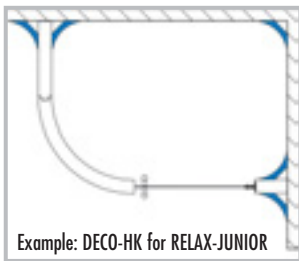

■ DECO-HK 100  
Concave trims, length 2500 mm

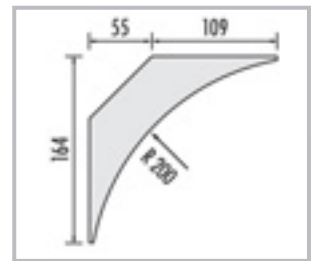

■ DECO-HK 200  
Concave trims, length 2500 mm

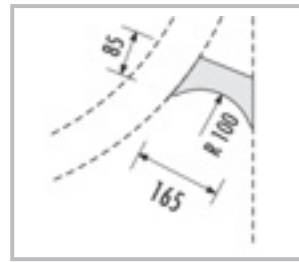
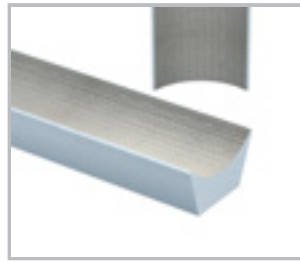

■ DECO-RD-HK  
Concave trim for RELAX-RD, length 2500 mm

### ■ DECO-... – curvature elements

Curvature elements made of hard foam support material. The DECO-AE semi-circular finishing element can be ordered to round off edges e.g. with RELAX-RD, RELAX-SD and RELAX-RSE (see page 29). The DECO-VE round cladding element in two sizes is used to round off corners outwards.

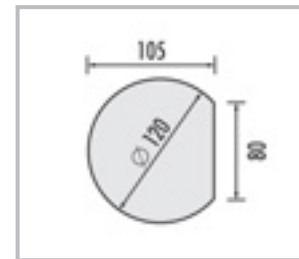
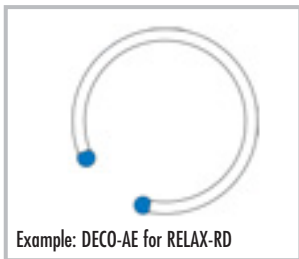

■ DECO-AE  
Finishing element for edges,  
Ø 120 mm, length 2500 mm

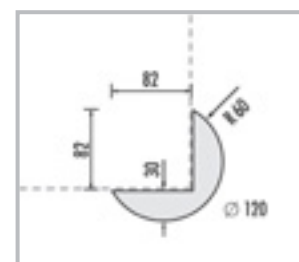
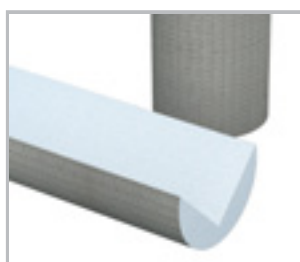
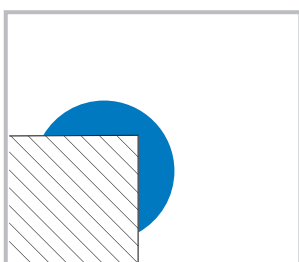

■ DECO-VE 120  
Round surrounding element for corners,  
Ø 120 mm, Länge 2500 mm

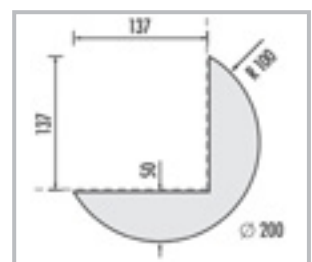

■ DECO-VE 200  
Round surrounding element for corners,  
Ø 200 mm, Länge 2500 mm



## ■ DECO-PM – pillars (columns)

dimensions in mm.

Columns made of hard foam support material are available as round models (PM R) for freestanding columns, half-round models (PM H) for wall mounting, and quadrantshaped models (PM-V) for room corners.

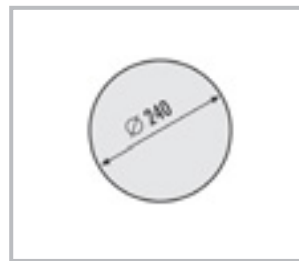
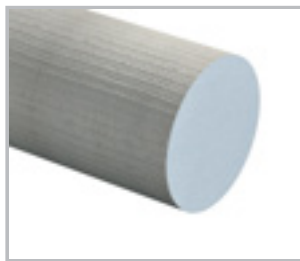
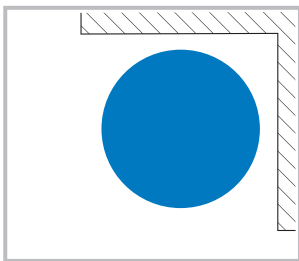

■ DECO-PM R  
Column, round  
∅ 240 mm, length 2500 mm

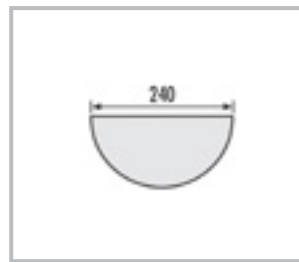
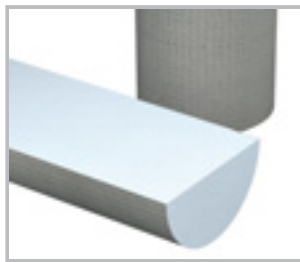
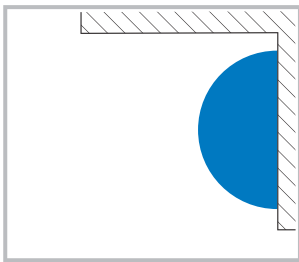

■ DECO-PM H  
Column, semi-circular  
∅ 240 mm, length 2500 mm

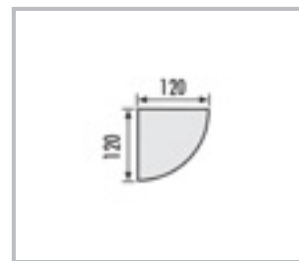
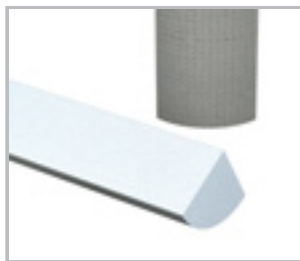
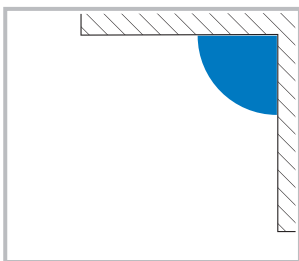

■ DECO-PM V  
Column, quadrant  
∅ 240 mm, length 2500 mm

### ■ Special formats – DECO-PLUS

You can not find the right product?

We also manufacture made-to-measure! Sizes, shapes, thicknesses etc., that do not correspond to the standard range can be enquired about separately at LUX ELEMENTS. After successful verification of the feasibility we will create a non binding offer.

Once we receive your order, the order will be manufactured.



### ■ NOTE:

For further information, please refer to our documents.

Data sheets, test certificates and processing instructions can be downloaded from [www.luxelements.com](http://www.luxelements.com) or visit our new YouTube-Channel on [www.youtube.com/user/luxelementscom](http://www.youtube.com/user/luxelementscom)

## LUX ELEMENTS®-FOAM

# Foam parts



The basic material for the products of LUX ELEMENTS is LUX ELEMENTS®-FOAM, a very high-quality, blue coloured, expanded polystyrene hard foam that is produced using an environmentally friendly technique without foaming agents which are harmful to the climate.

The good workability of this material and the production methods at LUX ELEMENTS enable individual and complex shapes to be manufactured.

The lightweight, waterproof and mold-resistant polystyrene hard foam can be used in various areas. Therefore a mortar coating is not always necessary.

Uncoated FOAM is available upon request as:

- Block
- Panel blank
- Shaped part

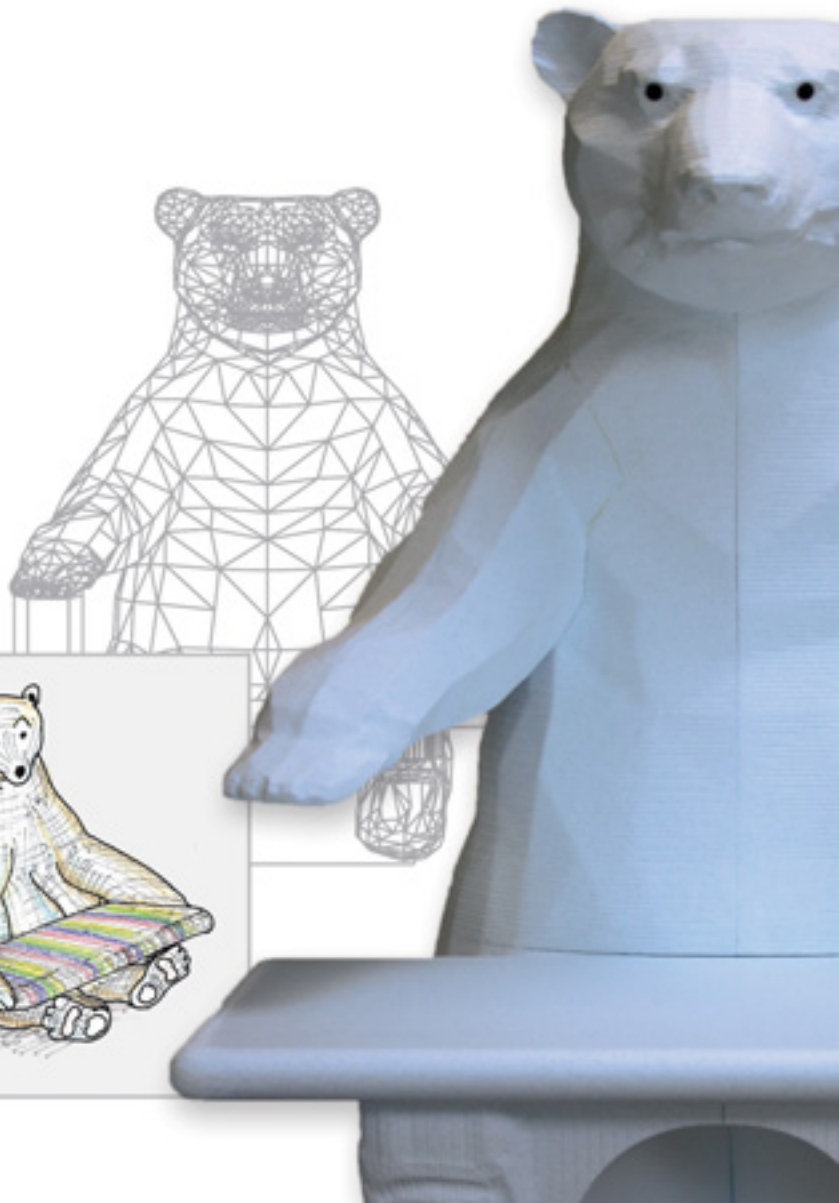
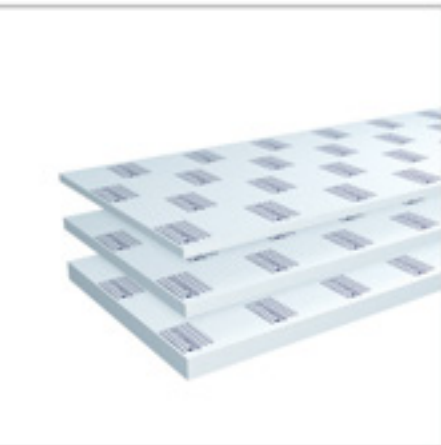

**LUX ELEMENTS – Individual concepts**  
Customised and special products

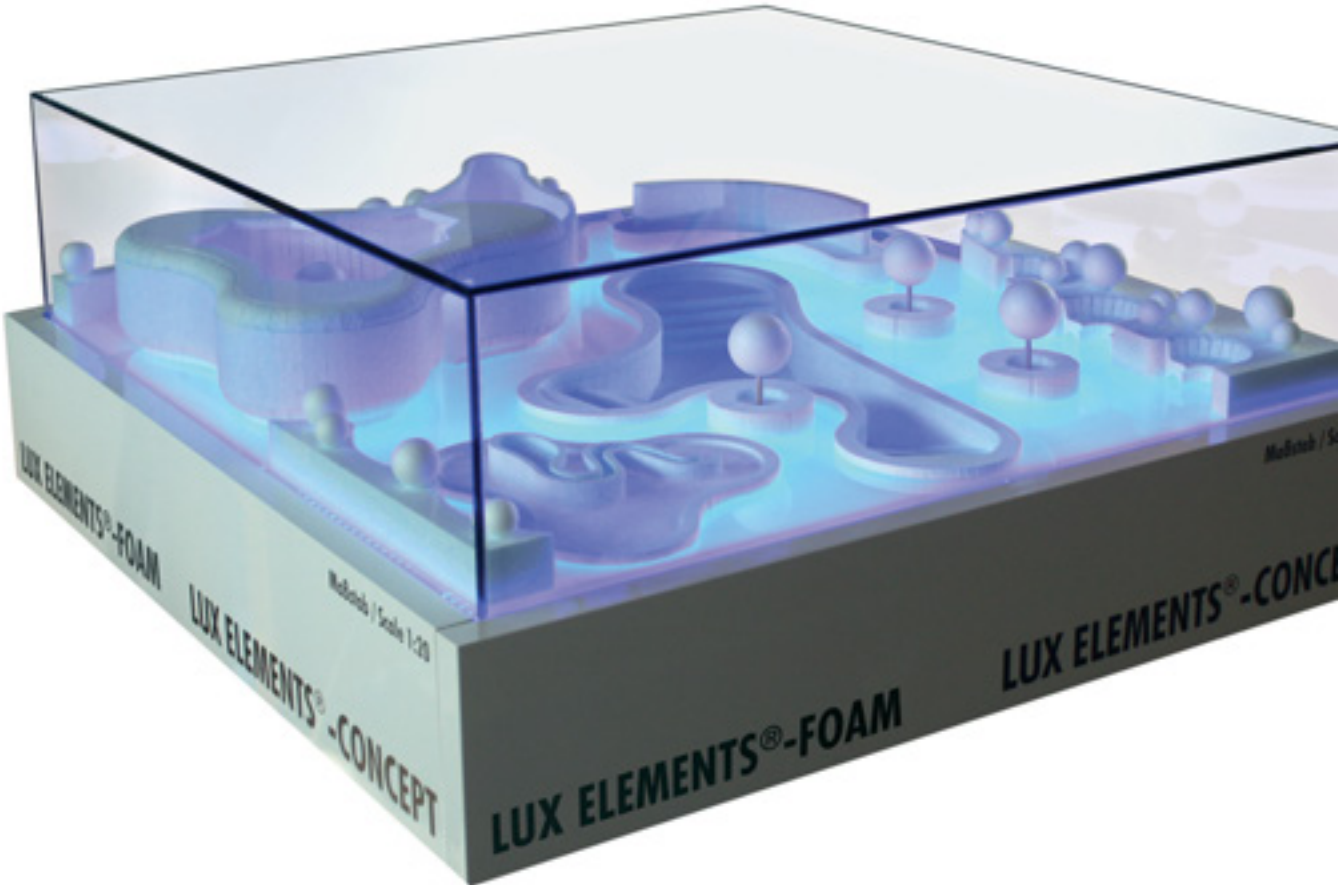

# LUX ELEMENTS – Individual concepts

## Customised and special products

## Technical solutions

### Special fixtures on request

LUX ELEMENTS hard foam support elements are easy to work with and therefore perfect for the integration of technical components. The necessary millings and sections etc. can be prepared at the factory or produced on site according to exact measurements.

For example:

#### ■ Heaters

Electrical and hot water heaters are installed beneath the ceramic tiles of benches, seats and loungers. Millings for the heating pipes can be prepared if required.

#### ■ Lighting and control technology

The fact that the material is so easy to work with facilitates the installation of very different control systems for wellness and spa facilities .

Further technical solutions (glass connections, fasteners for fittings, steam inlet) on pages 46 and 47.





# Technical solutions

## Special fixtures on request

### ■ Glass connections

A glass front – possibly with a glass door – offers maximum transparency for individual room constructions. We offer a solution for this, too:

Our glass profile constructions enable the combination of profile frames with block frames including glass door hinges as well as 8 mm single-pane safety glass (ESG safety glass).

The system is thus suitable for use as a glass front with or without a glass door. A window opening is also possible.

Embedded hard-plastic inlays (FIX-PRO-MAK) ensure the safety and stability of the connections to the hard foam support elements.

#### Connection variants

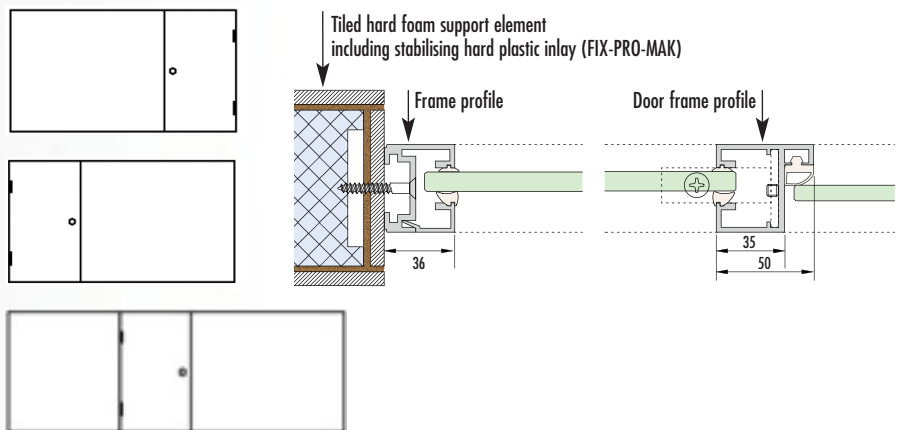

#### Profile connections

Frame profiles are connected to each other using connecting profiles with self-tapping screws.

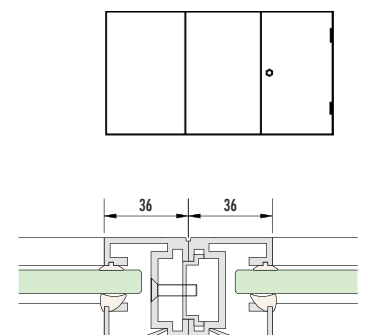

### Corner connections

Corner frame profiles are offered in 90° and 135° versions for corner connections. These are suitable for connection both to another frame profile and to a door frame.

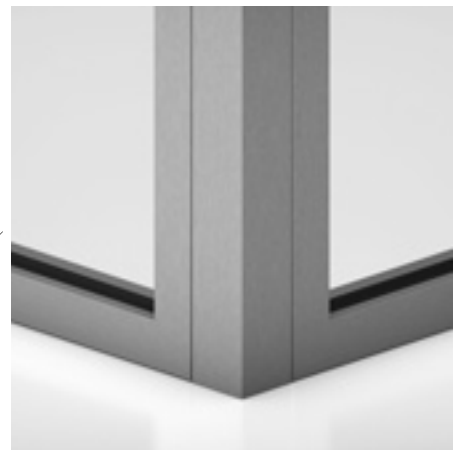
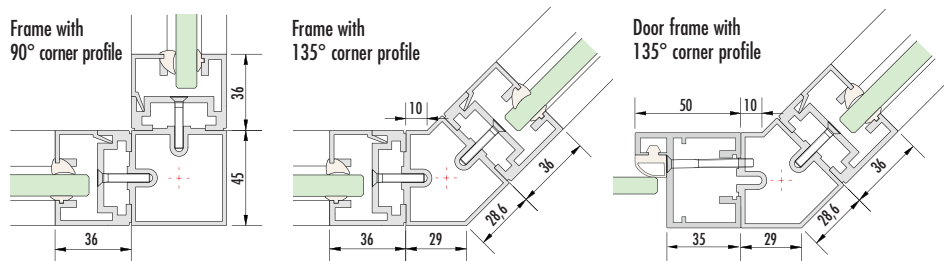

### Window opening

When installing a window, the mitre-cut frame profiles are connected across the corner using a special bracket. Connection to the hard foam support elements is done with screws.

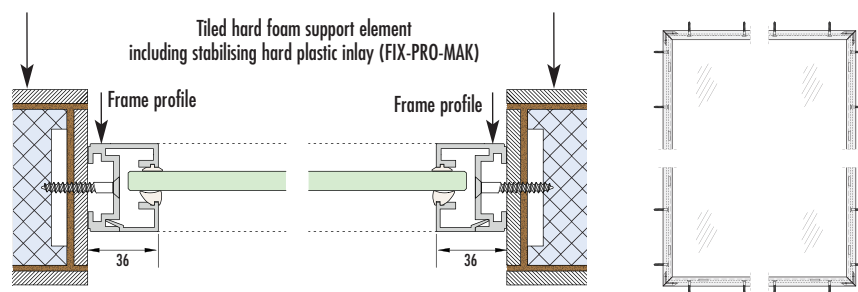

### Fittings

The FIX-IPA-... installation panel is available for the fastening of fittings, for example in showers. This can be ordered loose or integrated in the wall.

The panel is optionally available with pre-installed flush-mounted iBox from Hansgrohe plus the associated pipework or without equipment.

### Steam inlets

LUX ELEMENTS offers prefabricated support panels for a steam inlet for steam baths or steam showers. These are optionally available pre-integrated in the factory (FIX-DE-TI) or loose for self-assembly (FIX-DE-TE).

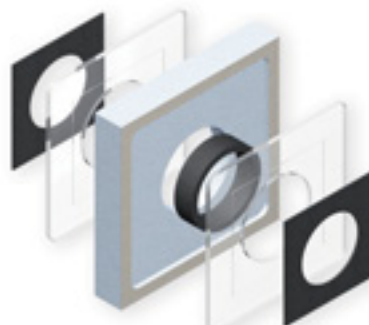

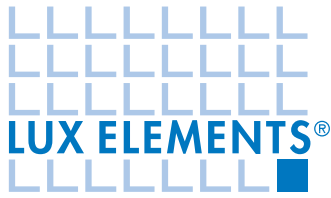

**LUX ELEMENTS – Individual concepts**  
Customised and special products

# LUX ELEMENTS as partner

**Our competence for your project**





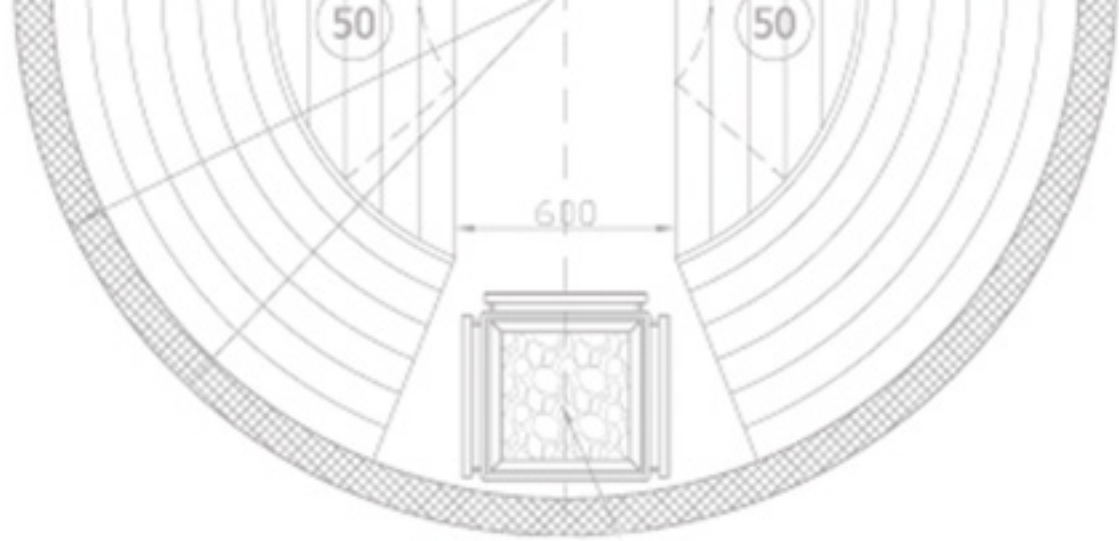

- **Decades of experience**  
in processing hard foam support elements
- **Modern flexible production methods**  
in our own production plants
- **Individual production**  
of your components as individual or series products
- **High level of technical expertise**  
owing to our own development department
- **International team**  
with multilingual contacts
- **Professional advice**  
by experienced employees
- **Quality control from the start**  
through entirely in-house production
- **Certified quality management**

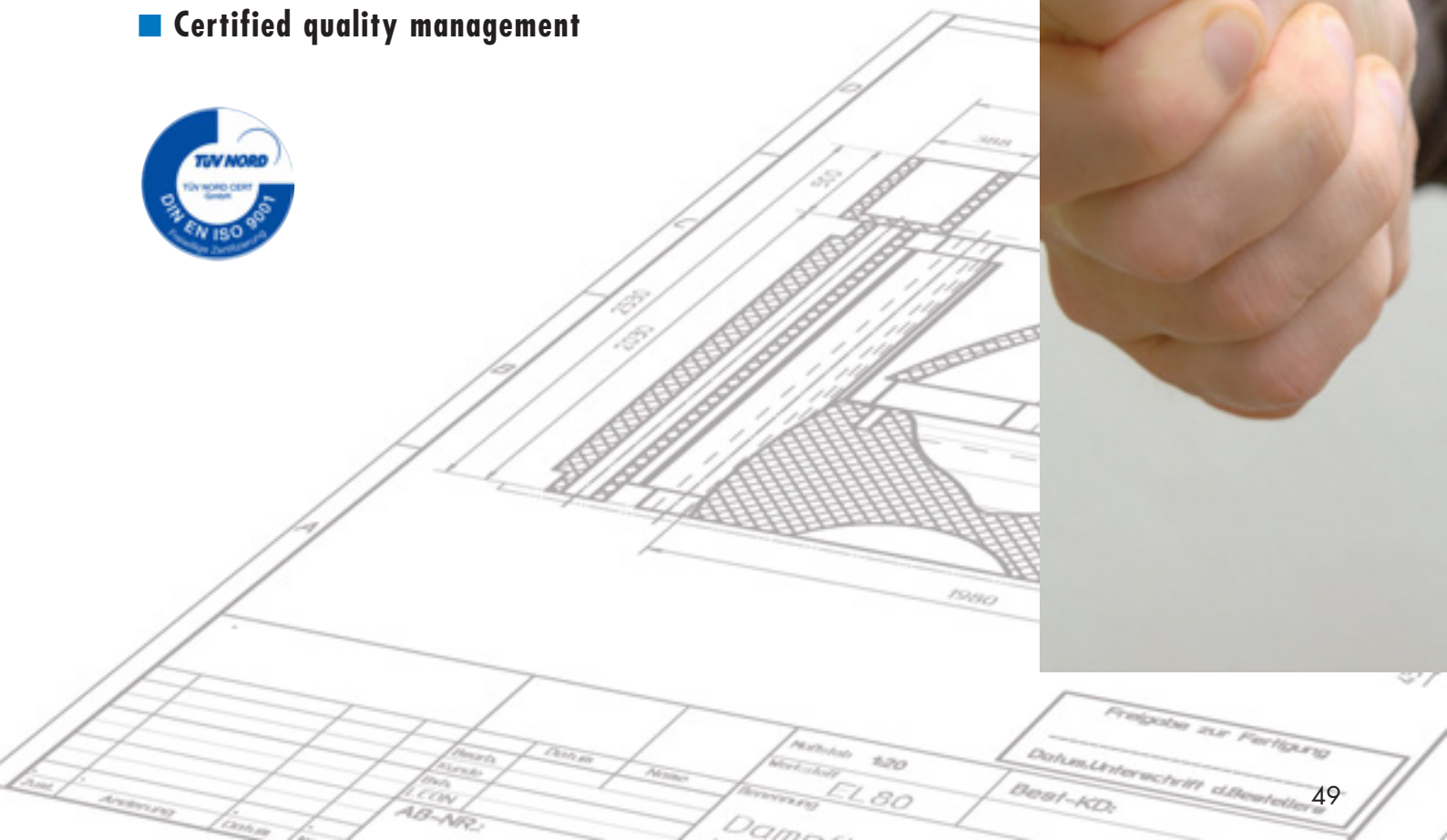

# From planning to finished item

**We are with you all the way!**

In the case of custom-made products we implement your planning. And we keep up a constant dialogue with you to support you throughout the planning and assembly phases.



**For example:**

- Room constructions and steam baths
- Experience showers/shower units
- Kneipp baths and foot baths
- Pools and underwater worlds
- Partition walls
- Decorative elements
- Heated loungers and benches
- Complete solutions from a single source

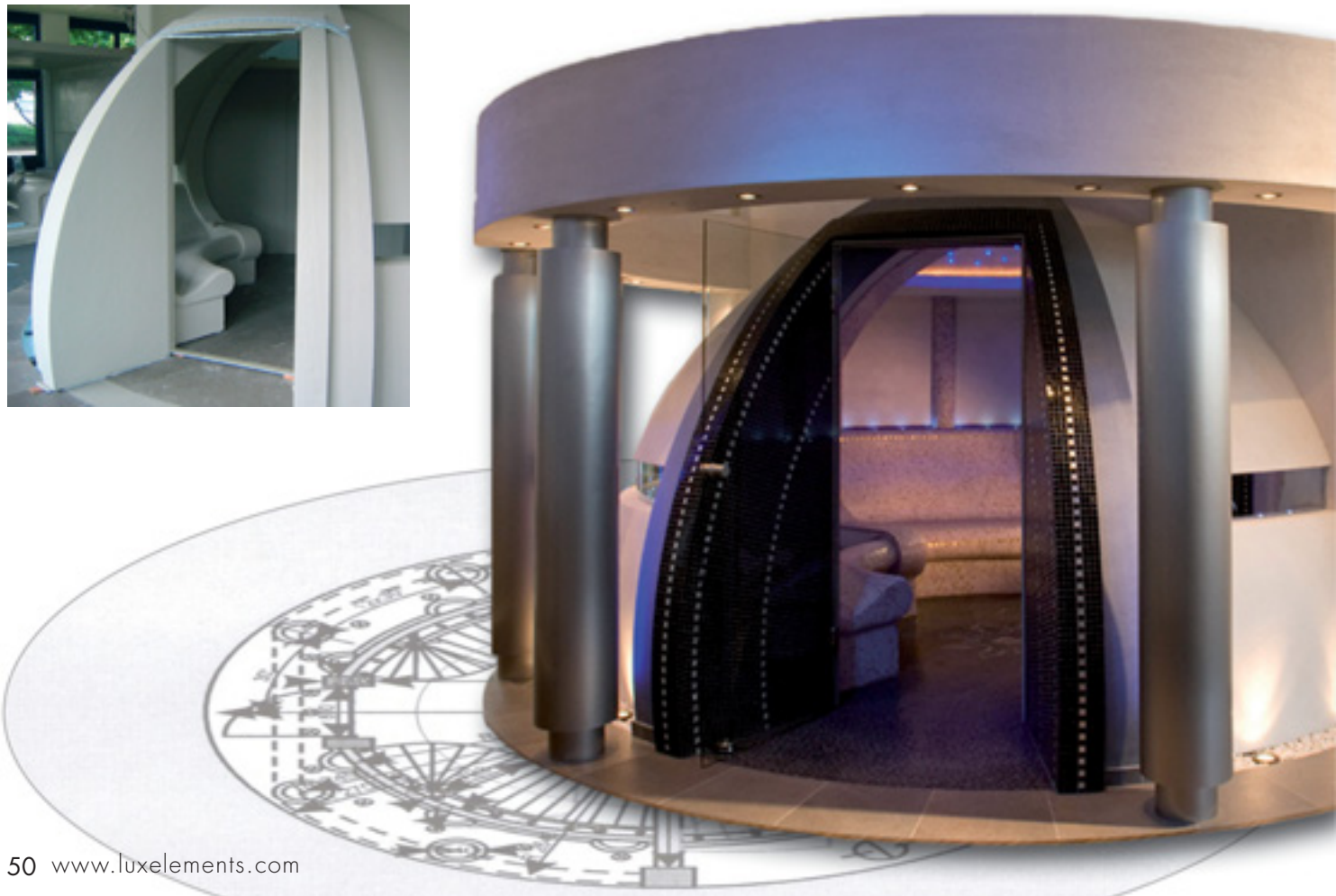

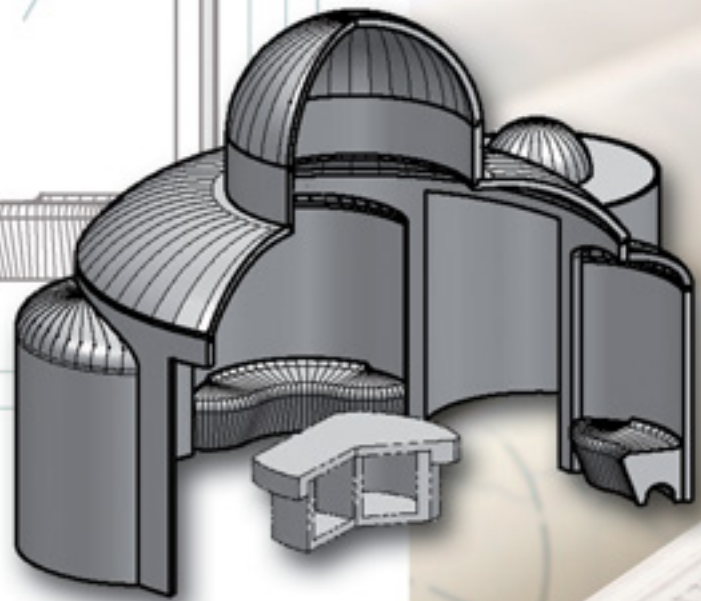
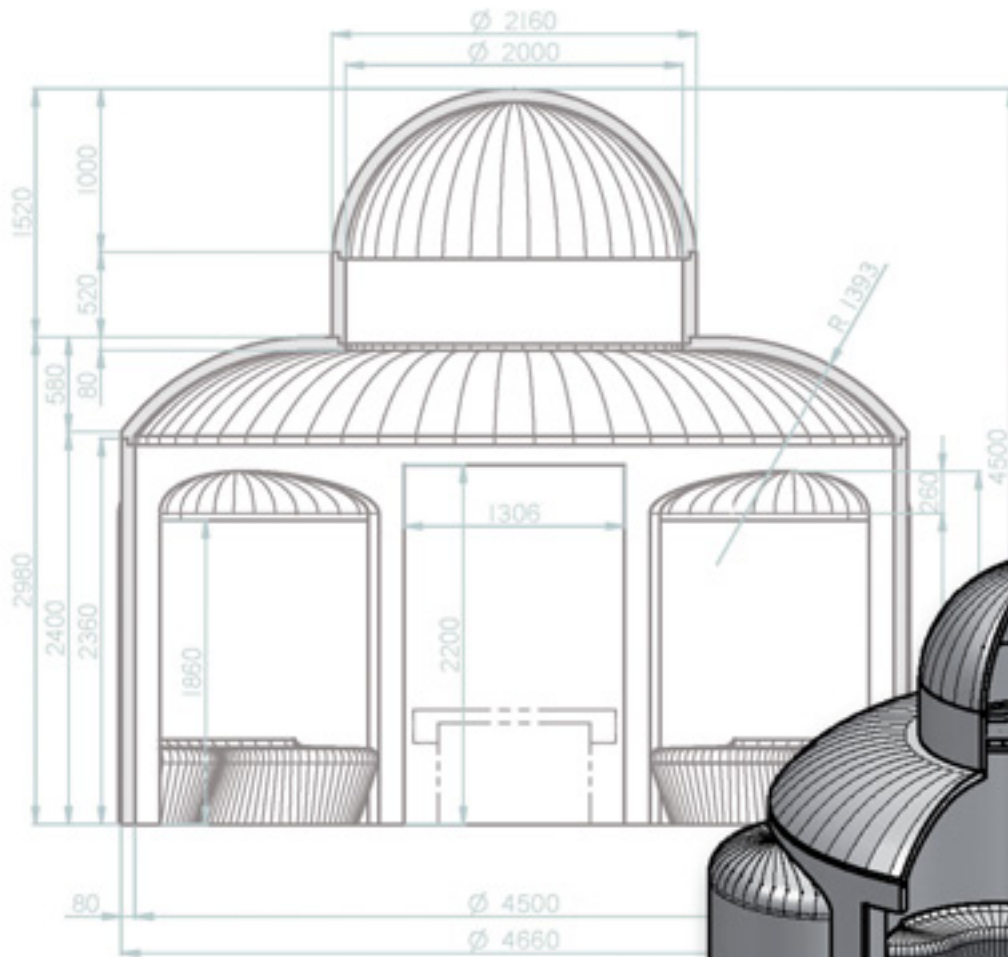

# Step 1

## Idea and planning

You can give free rein to your ideas at the planning stage. The **modern, flexible production methods** at LUX ELEMENTS make it possible to produce large items and a wide range of shapes.

In accordance with your specifications we produce a **technical drawing** for approval. Our integrated **3D display** helps you to envisage the drawing particularly well.

On request and especially with large components we also take care of the **structural analysis**.

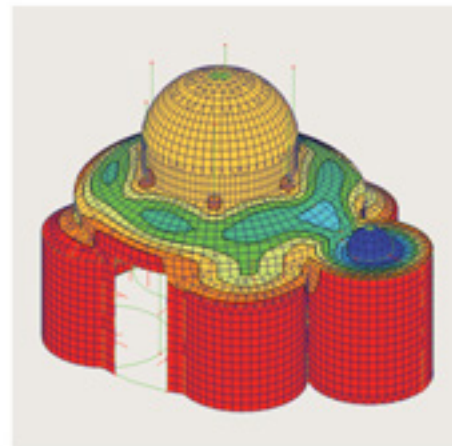
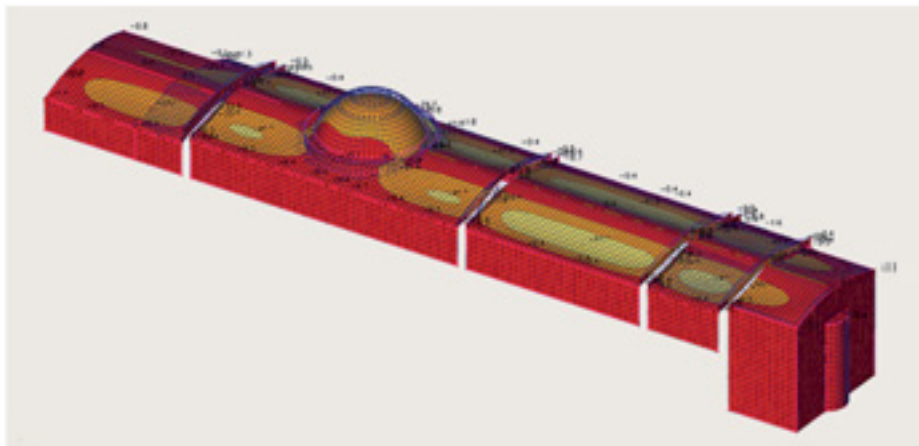



# LUX ELEMENTS – Individual concepts

## Customised and special products

### Step 2

#### Order and production

After receiving your order, LUX ELEMENTS produces the components **precisely** according to your plans and specifications.

To check the fitting accuracy of the components, we **test the assembly** of the whole item in our workshop before delivery. All the parts are **numbered** according to the installation plan, which is a considerable help to the installers on site.

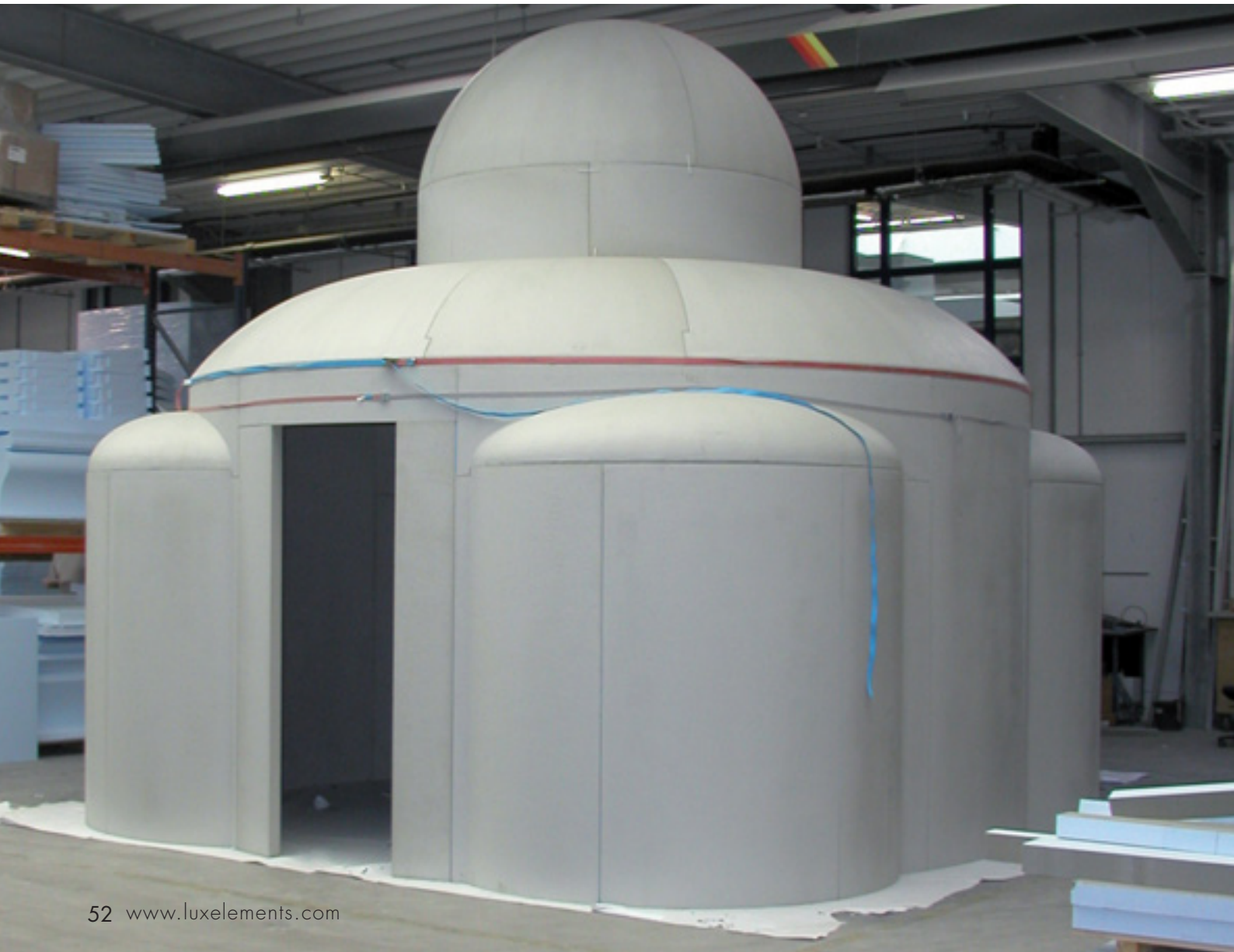



## Step 3

### **Assembly and arrangement**

Delivery in segments is a major advantage since it means the components are lighter and can also be transported in confined spaces. The prefabrication of the elements and short drying times ensure time and therefore cost savings during assembly.

Fittings and other technical components are installed directly on site. The materials are easy to work with, which makes installation trouble free.



We are able to do far more...

**More information on LUX ELEMENTS  
on the Internet**

Current information on the company and all products are available 24 hours a day on our homepage [www.luxelements.com](http://www.luxelements.com)

- Practical tips
- Latest news
- Trade fair and seminar dates
- Media coverage

can all be found here, also national and international contact addresses and a description of the production process at LUX ELEMENTS.

# LUX ELEMENTS – Individual concepts

## Customised and special products

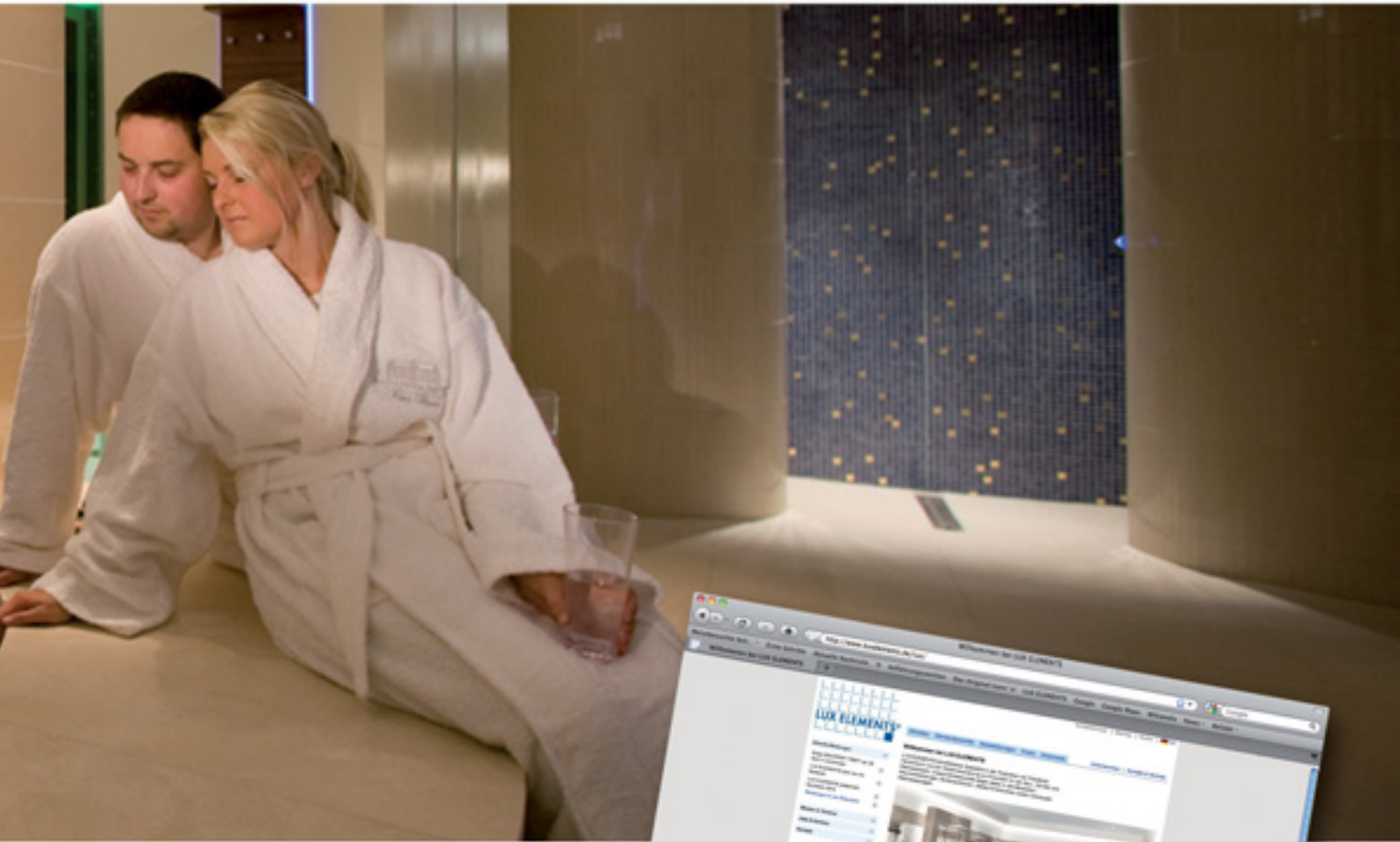

The detailed product and processing pages are supplemented by a wide range of **downloads**:

- Datasheets
- Test certificates
- Brochures
- Tender specification texts

You can download a PDF of any information you require.

Would you like more information regarding our **training courses** or do you need a **personal consultation**?

Please make use of our contact form. We look forward to your mail!

[http://www.luxelements.de/lux\\_en/kontakt/anfrage.htm](http://www.luxelements.de/lux_en/kontakt/anfrage.htm)

The handbook for “Hydrothermal Spa Development Standards” – guidelines for an approach to the planning and construction of spa complexes in the public and private sector – was created with the editorial participation of LUX ELEMENTS.



+49 (0) 21 71 / 72 12 10

# Fax order form

## Order more information

(Please enter the quantity and desired language!)

■ PROGRAM	<input type="checkbox"/> ___ pcs. / <input type="checkbox"/> PDF (E-Mail)	<input type="radio"/> DE <input type="radio"/> FR <input type="radio"/> NL <input type="radio"/> EN		
■ THE CONSTRUCTION – Designing with hard foam support elements	<input type="checkbox"/> ___ pcs. / <input type="checkbox"/> PDF (E-Mail)	<input type="radio"/> DE <input type="radio"/> FR <input type="radio"/> NL <input type="radio"/> EN		
■ THE EXPERIENCE – Shower bases	<input type="checkbox"/> ___ pcs. / <input type="checkbox"/> PDF (E-Mail)	<input type="radio"/> DE <input type="radio"/> FR <input type="radio"/> NL <input type="radio"/> EN		
■ INDIVIDUAL CONCEPTS – Customised and special products	<input type="checkbox"/> ___ pcs. / <input type="checkbox"/> PDF (E-Mail)	<input type="radio"/> DE <input type="radio"/> FR <input type="radio"/> NL <input type="radio"/> EN		
■ DETAILED DESCRIPTIVE LITERATURE	___ pcs.	<input type="radio"/> DE <input type="radio"/> FR <input type="radio"/> NL <input type="radio"/> EN		
■ ADVICE	<input type="checkbox"/> Yes, I am interested in an appointment, please call me.			
SECTOR:	<input type="checkbox"/> Architect <input type="checkbox"/> Plumber	<input type="checkbox"/> Tile retailer <input type="checkbox"/> Bathroom designer	<input type="checkbox"/> Tile installer <input type="checkbox"/> Installer	<input type="checkbox"/> Building materials retailer <input type="checkbox"/> Others

COMPANY: \_\_\_\_\_

CONTACT: \_\_\_\_\_

ADDRESS: \_\_\_\_\_

POSTAL CODE/TOWN: \_\_\_\_\_

TEL: \_\_\_\_\_

FAX: \_\_\_\_\_

E-MAIL: \_\_\_\_\_



**EUF**

The EUF (European Union of National Tile Associations) has developed the concept "Healthier Living with Ceramics" together with its European member associations and sponsor members. This concept is intended as information "pro tile" for trade, dealers and manufacturers. LUX ELEMENTS is the force behind the project and is actively involved in its implementation.



**(D)**

**LUX ELEMENTS GmbH & Co. KG**

An der Schusterinsel 7  
D - 51379 Leverkusen-Opladen

Tel. +49 (0) 21 71/72 12-0

Fax +49 (0) 21 71/72 12-10

E-Mail [info@luxelements.de](mailto:info@luxelements.de)

Web [www.luxelements.com](http://www.luxelements.com)

**(F)**

**LUX ELEMENTS S.A.S**

ZI-31, rue d'Ensisheim

F - 68190 Ungersheim

Tél. +33 (0) 3 89 83 69 79

Fax +33 (0) 3 89 48 83 27

E-Mail [info@luxelements.fr](mailto:info@luxelements.fr)

Web [www.luxelements.fr](http://www.luxelements.fr)