

MADE IN GERMANY



WETROOM PRODUCTS

Secure. Fast. Individual.



www.luxelements.ca



LUX ELEMENTS – WETROOM PRODUCTS

Secure. Fast. Individual.

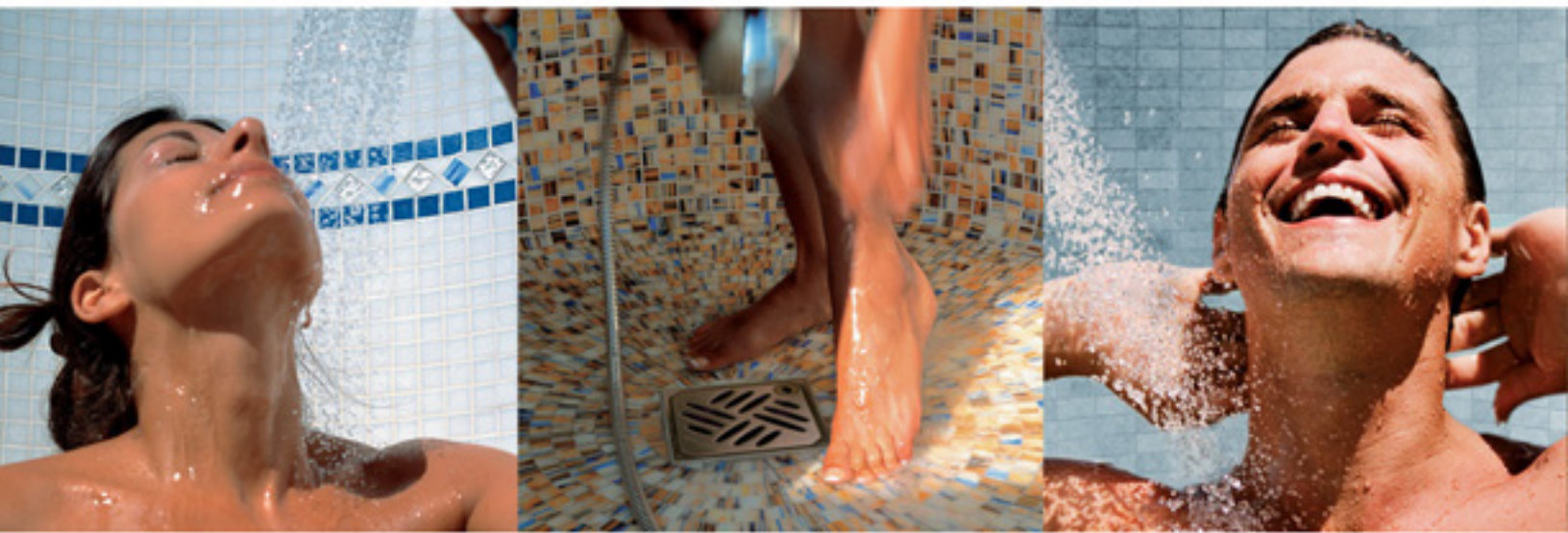

Quality made in Germany

**Wetroom products from LUX ELEMENTS
proven worldwide**

- Decades of experience
- High level of technical expertise
- International team
- Professional advice and support
- Modern flexible production methods
- Tried and tested building materials
- Quality control from the start
- Certified quality management

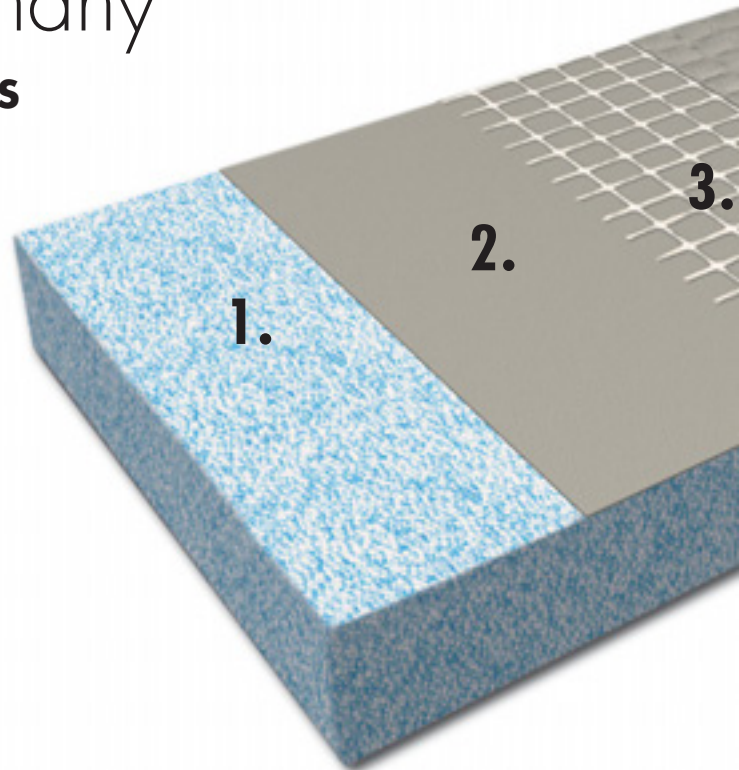



LUX ELEMENTS® - THE ORIGINAL

- Environment-friendly
- Modern building material
- Proven material advantages
- Excellent for use in wet and humid conditions
- Very good machinability
- Continuous development
- Modern, system-oriented product range

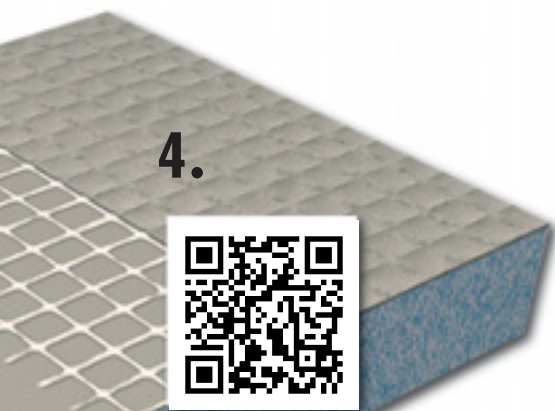

4.

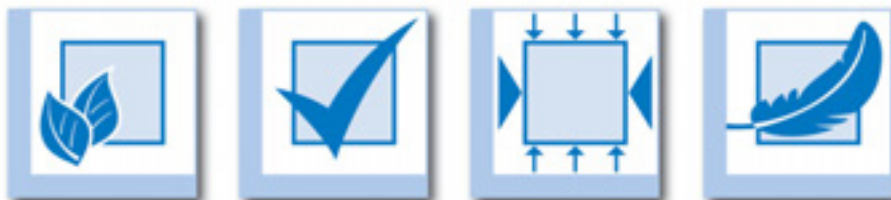

- environmentally friendly
- proven quality
- pressure-stable and rigid
- lightweight



- water-resistant
- fire-retarding
- insulating
- mould-resistant



- design variety
- alternative surfaces
- economical
- system-oriented

The ORIGINAL can do!

1. Polystyrene hard foam
2. Contact mortar layer
3. Glass fibre fabric
4. Coating mortar layer



LUX ELEMENTS – WETROOM PRODUCTS

Secure. Fast. Individual.

The wetroom solution system

LUX ELEMENTS®
Wall and floor panels

LUX ELEMENTS®
Benches

LUX ELEMENTS®
Shower bases
and drain system

LUX ELEMENTS®
Curbs and Ramps

All components from a single source

The wetroom is exposed to many stresses such as water, steam and heat. The water-resistant and mould-resistant hard foam support elements from LUX ELEMENTS are the appropriate material for the substrate here.

- Wall and floor panels
 - Bath surrounds
 - Shower bases and drain system
 - Benches
 - Niches
 - Curbs and Ramps
 - Washstands
- and
- Accessories

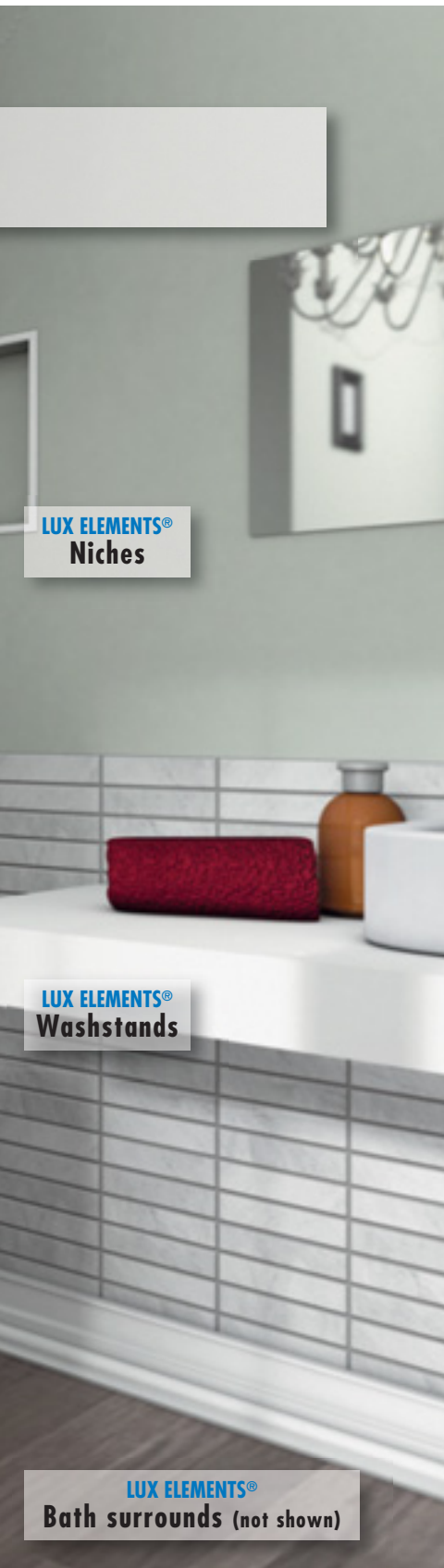

LUX ELEMENTS®
Niches

LUX ELEMENTS®
Washstands

LUX ELEMENTS®
Bath surrounds (not shown)



Invest in a secure wetroom solution – invest in LUX ELEMENTS® wetroom solution system!

LUX ELEMENTS has developed high quality waterproof flooring and walling systems to deal with the demands of both old and modern buildings. Whether the substrate is solid or wooden LUX ELEMENTS will ensure peace of mind and a longer life for the tiles.

- Complete system
- High-quality products from Germany
- Certified sealing system
- Perfectly matched components
- Full cost control due to system quotation
- Fast, trouble-free realisation
- Safe investment, long-term use

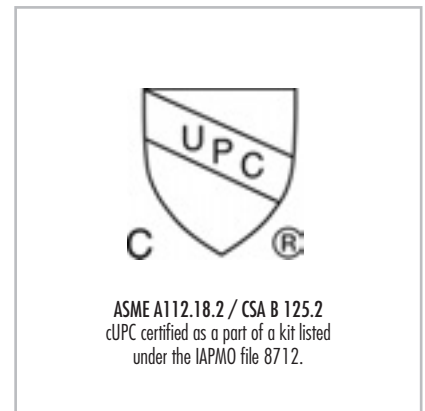

Double Security with second drainage level

Tiles and grout are not watertight! LUX ELEMENTS is one of the few companies who provide a solution when water passes through the grout and tiles and on to the waterproof layer.

- **Evacuates the water even when it gets under the tiles**
- **Ensures tiles stay firmly fixed to the tray**
- **Adhesives are not affected sitting in water**
- **Keeps the grout in better condition**
- **Furthers the life of the wetroom floor**

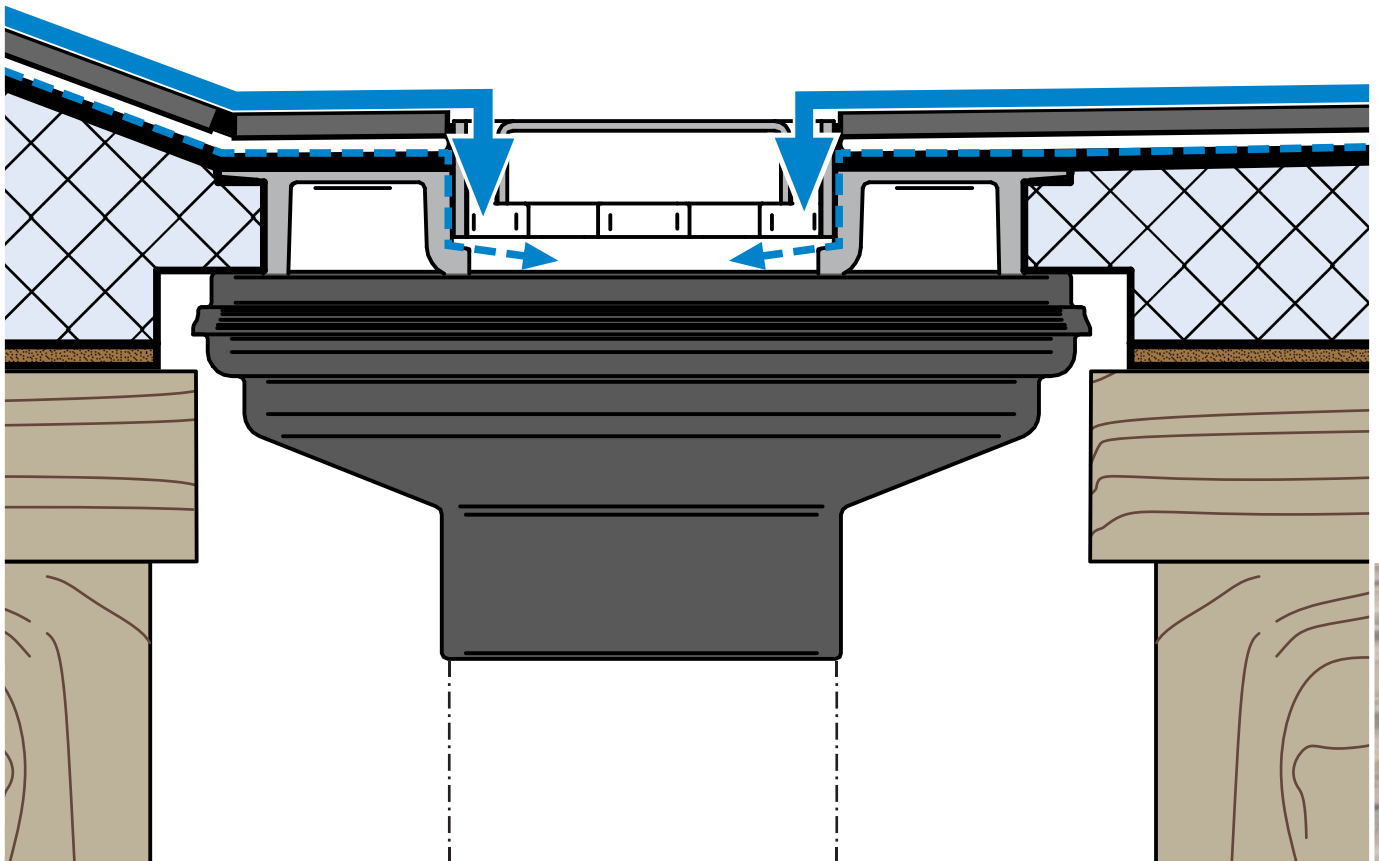



LUX ELEMENTS – WETROOM PRODUCTS

Secure. Fast. Individual.



Wall and floor panels

The universal construction panel

LUX ELEMENTS®-ELEMENT-EL is a support element made of polystyrene hard foam with mortar coating and glass fibre fabric on both sides. The panel is a more suitable material for wetroom construction than plasterboard and wood.

- **Reliable on the wall**
- **Creative in design**
- **Strong on the floor**
- **Ready for tiling**
- **Easy-to-use**
- **Versatile in everyday practice**



Wall and floor panels

Specifications



LUX ELEMENTS – WETROOM PRODUCTS

Secure. Fast. Individual.

■ LUX ELEMENTS®-ELEMENT-EL ...

The construction panels from the ELEMENT product group are available in many thicknesses and designs for different areas of application. They are suitable for use on the wall, as well as on the floor.



For further information, please refer to our documents. Data sheets, test certificates and processing instructions can be downloaded from www.luxelements.ca



ASME A112.18.2 / CSA B 125.2
The panels are cUPC certified as a part of a kit listed under the IAPMO file 8712.

LUX ELEMENTS®-ELEMENT-EL 1524/900 12

The universal construction panel especially for the Canadian market dimensions:

1524 x 900 x 12 mm · 5' x 3' x 1/2"

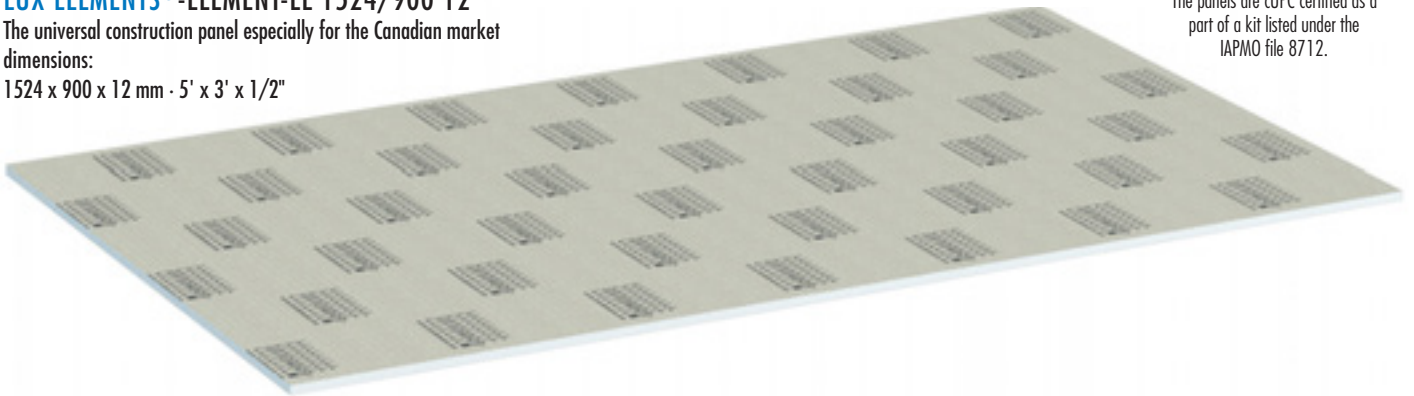

Wall cladding on stud frames



Floor protection

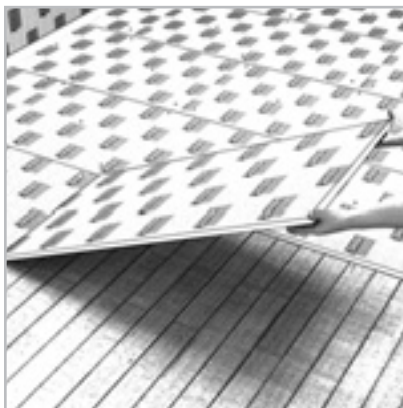

Floor leveling with shower base flush with the floor

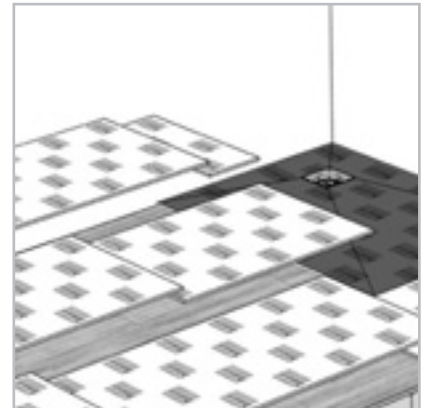



LUX ELEMENTS – WETROOM PRODUCTS

Secure. Fast. Individual.

Bath tub surrounds

Ready for tiling

LUX ELEMENTS®-TOP-TR... are prefabricated bath tub surrounds for rectangular standard bath tubs.

Available are three different design variants for bath tub surrounds:

- Surrounds for smooth and flush bath cladding
- Surrounds with footboard
- Surrounds with ledge





Bath tub surrounds

Specifications



■ Surrounds with LUX ELEMENTS®-TOP-TR...

Bath tub surrounds for rectangular standard bath tubs.
Available are three different design variants:

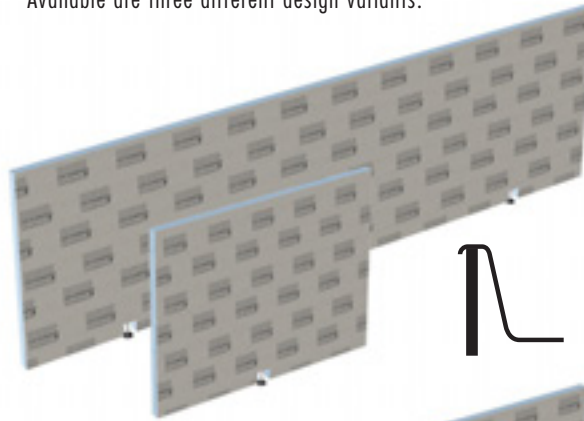

LUX ELEMENTS®-TOP-TRS

Surrounds for smooth and flush bath cladding for bath tubs up to 2100 mm · 82 11/16" and bath tub head end

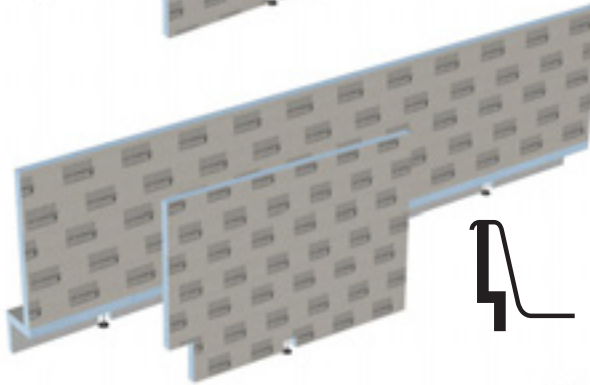

LUX ELEMENTS®-TOP-TRU

Surrounds with footboard for bath tubs up to 2100 mm · 82 11/16" and bath tub head end

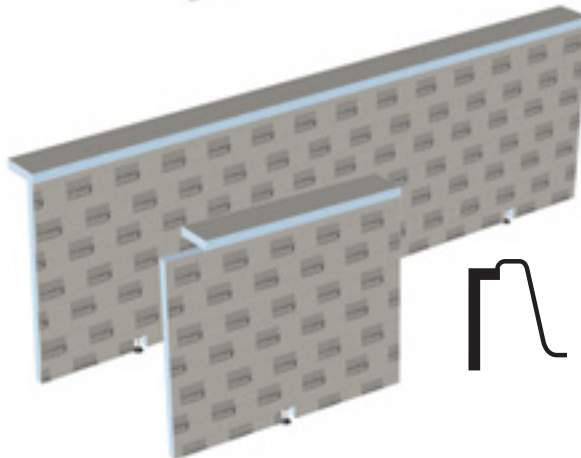

LUX ELEMENTS®-TOP-TRV

Surrounds with ledge for bath tubs up to 2100 mm · 82 11/16" and bath tub head end



Please note:
Bath tub surrounds for standard rectangular tubs are not available as kits. Depending on the installation situation as many as 4 elements are needed.

LUX ELEMENTS – WETROOM PRODUCTS

Secure. Fast. Individual.

For the three design variants the following installation positions are possible:

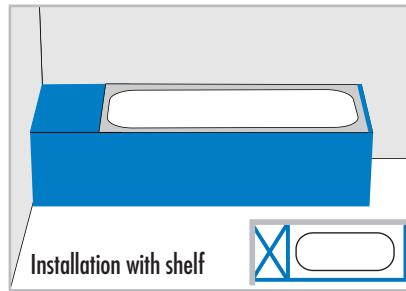
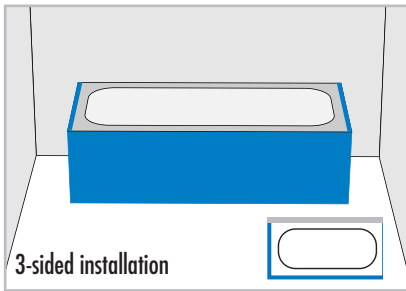
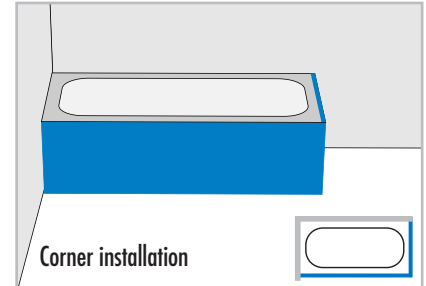
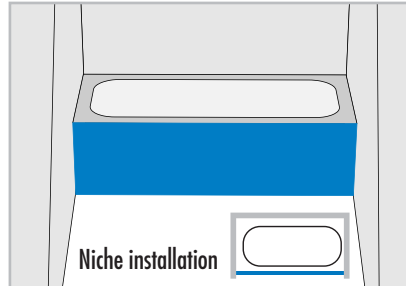
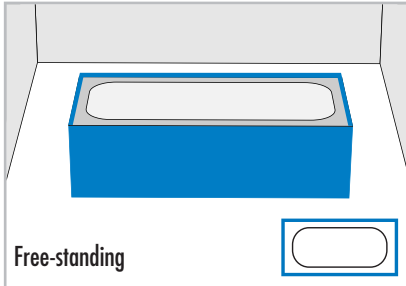

For further information, please refer to our documents. Data sheets, test certificates and processing instructions can be downloaded from www.luxelements.ca



■ Inspection options and mounting aids for TOP-TR...

Two solutions are available to choose from for maintenance and repair. LUX ELEMENTS offers complete mounting kit and mounting aid for bath tub surrounds.

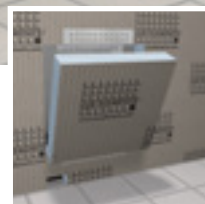



LUX ELEMENTS – WETROOM PRODUCTS

Secure. Fast. Individual.

Shower bases and drain system

The centrepiece of the shower area is the shower base. Whether in a corner or as a replacement for a bath tub, whether as a step up on the floor or a flush with the floor solution, LUX ELEMENTS offers a suitable model for every application in two drainage versions, point and linear.

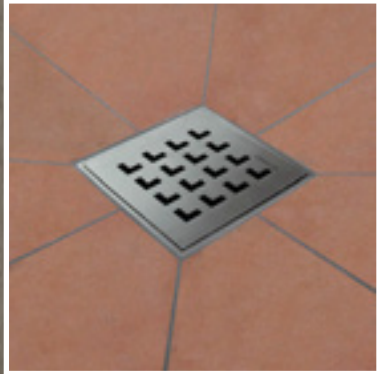



LUX ELEMENTS – WETROOM PRODUCTS

Secure. Fast. Individual.

Shower bases and drain system

- Models for every installation situation
- For concrete and wooden substrates
- With point drainage or floor channel drain
- Large range of matching accessories
- Made-to-measure designs are also possible





Shower bases and drain system

Point drainage – Specifications

■ LUX ELEMENTS®-TUB – design variants

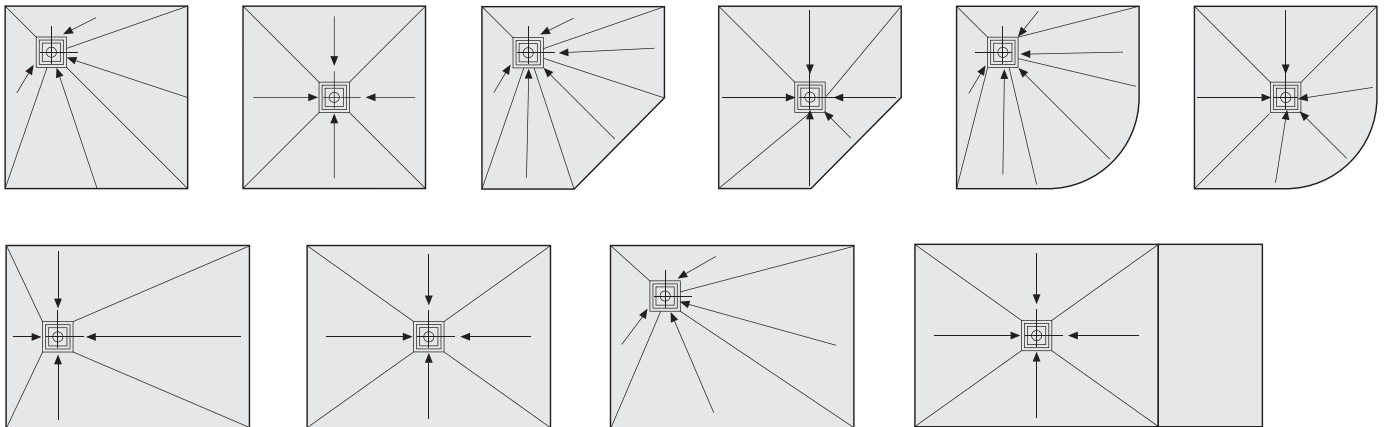

For further information, please refer to our documents. Data sheets, test certificates and processing instructions can be downloaded from www.luxelements.ca

■ LUX ELEMENTS®-TUB – the principle

Point drainage

with height-adjustable grate fitting frame and standard or design grate

1

Shower base element

equipped with factory-fitted seal and slope as well as sealed-in grate for high security

2

Floor drain support

Fits all LUX ELEMENTS® shower base elements
Secure and fast installation by means of click system, cUPC certified

3



ASME A112.18.2 / CSA B 125.2
The drains are cUPC certified as a part of a kit listed under the IAPMO file 8712.

Make your choice ...



■ Drain grates for every taste

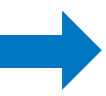

TUB-RA-DA



TUB-RA-DC



TUB-RA-DL



TUB-RA-DM



TUB-RA-DV



TUB-RA-DS

with locking system



TUB-RA-DF

with locking system



TUB-RA-S

standard grate

Shower bases and drain system

Linear drainage – Specifications

■ LUX ELEMENTS®-TUB-LINE – design variants

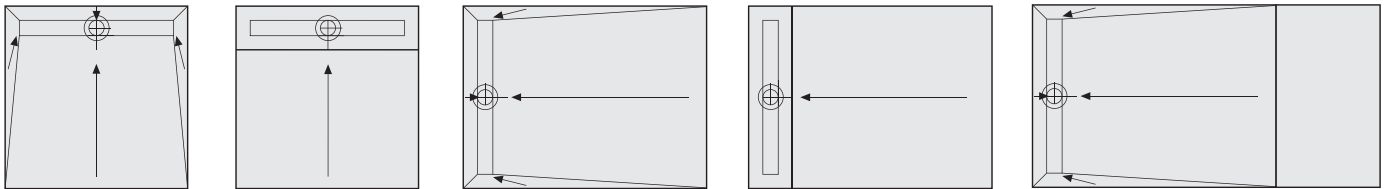

For further information, please refer to our documents. Data sheets, test certificates and processing instructions can be downloaded from www.luxelements.ca

■ LUX ELEMENTS®-TUB-LINE – the principle

Linear drainage

with reversible cover rail for two surface variants, tiled or stainless steel, height-adjustable.



1

Shower base element

equipped with factory-fitted seal and slope as well as channel fitting frame for high security.

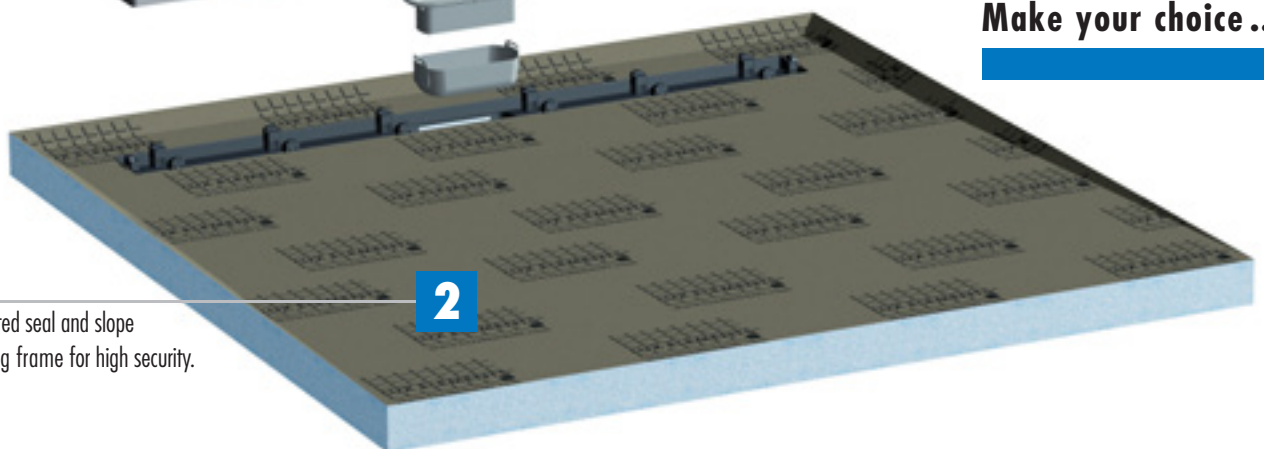

2

Floor drain support

Fits all LUX ELEMENTS® shower base elements
Secure and fast installation by means of click system, cUPC certified

3

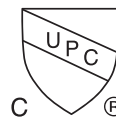

ASME A112.18.2 / CSA B 125.2
The drains are cUPC certified as a part of a kit listed under the IAPMO file 8712.

Make your choice ...



■ Design cover rail



cover rail tiled



cover rail turned, brushed stainless steel

■ Two gradient variants



4-sided gradient



single-sided gradient

Shower bases and drain system

Support

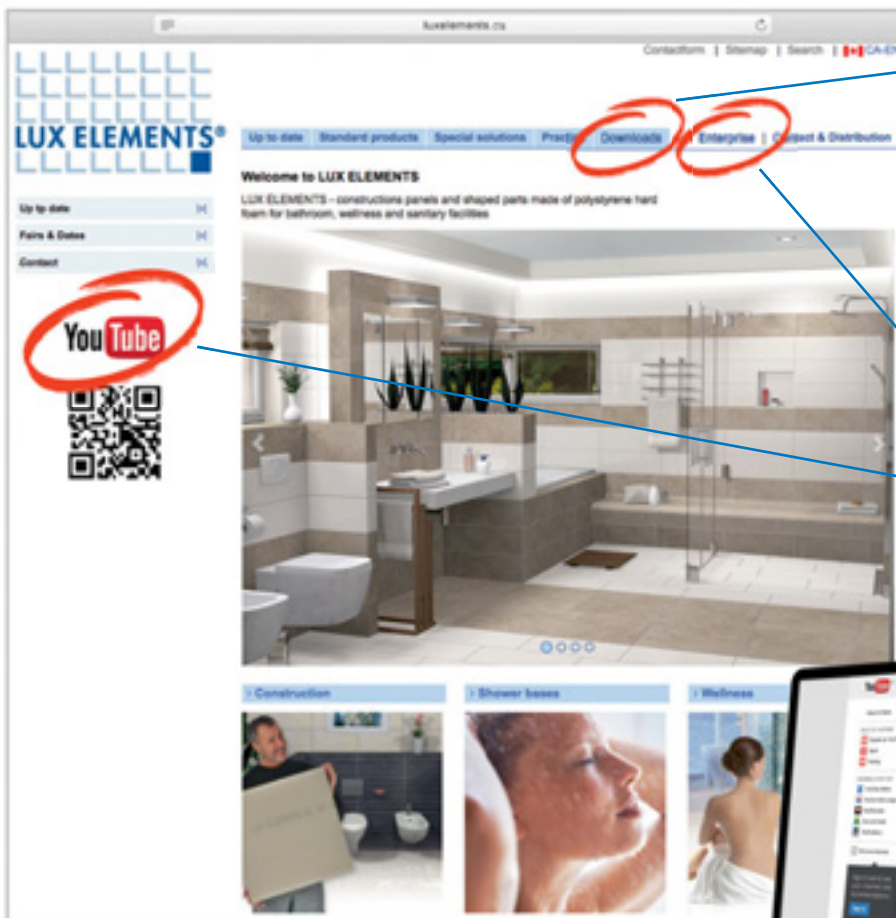

- **Downloads:**
 - Data sheets,
 - Test certificates,
 - Product & packaging specifications,
 - Processing instructions,
 - Brochures
- **Certified Contractors and Authorized Retailers**
- **Installation videos**

www.luxelements.ca

Take a look ...



- **Our mobile website for smartphones, tablets and other mobile devices**



LUX ELEMENTS – WETROOM PRODUCTS

Secure. Fast. Individual.

You can not find the right product?

We also manufacture shower bases made-to-measure!

- **Special formats called 'TUB-PLUS' can be enquired about separately**
- **After successful verification of the feasibility we will create a non binding offer**
- **Once we receive your order, the order will be manufactured**

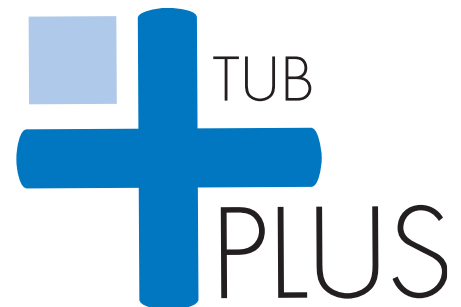



LUX ELEMENTS – WETROOM PRODUCTS

Secure. Fast. Individual.

Benches

for corner or at straight wall



A shower area with a seat is particularly practical. LUX ELEMENTS offers prefabricated models for the corner in a compact or “floating” design as well as a wall-mounting seat in two widths.



LUX ELEMENTS – WETROOM PRODUCTS

Secure. Fast. Individual.

Benches

Specifications

■ Bench seat corner



LUX ELEMENTS®-RELAX-BA-CO

bench seat corner, solid

dimensions:

816 x 577 x 508 mm

32 1/8" x 22 11/16" x 20"

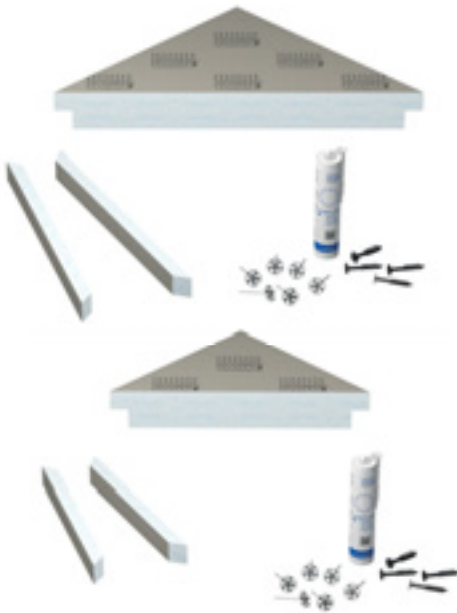

LUX ELEMENTS®-RELAX-BA-CO FLOAT ...

bench seat corner, floating, with assembling kit:

- 1 cartridge mounting adhesive COL-MK
- 6 fastening sets FIX-SB 80S35
- 4 special screw plugs FIX-SD 80

RELAX-BA-CO FLOAT L

large, dimensions:

864 x 610 x 100 mm

34" x 24" x 3 15/16"

RELAX-BA-CO FLOAT S

small, dimensions:

610 x 430 x 100 mm

24" x 16 15/16" x 3 15/16"

■ Bench straight

LUX ELEMENTS®-RELAX-BA-SOLO-G ...
bench form SOLO, straight

RELAX-BA-SOLO-G 900

dimensions:

900 x 500 x 450 mm

35 7/16" x 19 11/16" x 17 11/16"

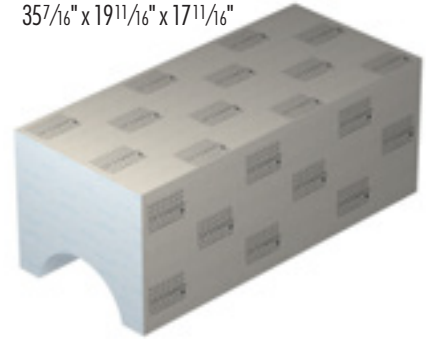

RELAX-BA-SOLO-G 750

dimensions:

750 x 500 x 450 mm

29 1/2" x 19 11/16" x 17 11/16"

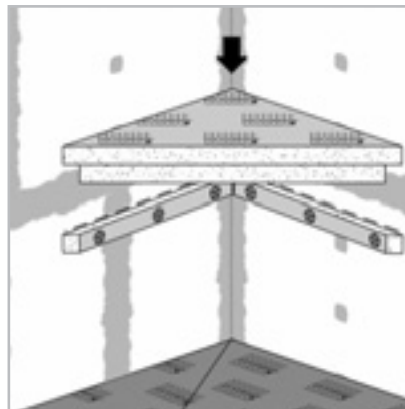
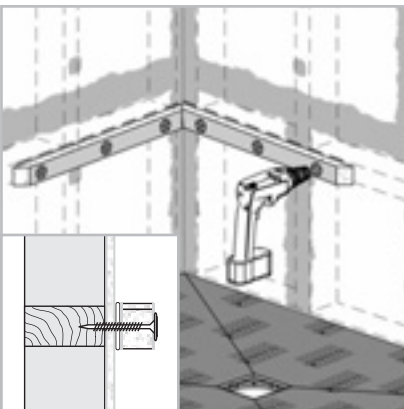
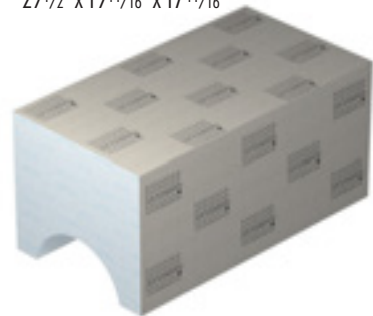

For further information, please refer to our documents. Data sheets, test certificates and processing instructions can be downloaded from www.luxelements.ca



LUX ELEMENTS – WETROOM PRODUCTS

Secure. Fast. Individual.

Niches

The space-saving solution

Niches are an elegant and space-saving solution for shelves. LUX ELEMENTS offers four prefabricated niches made of hard foam support material which can be combined ideally with LUX ELEMENTS®-ELEMENT-EL wall panels.





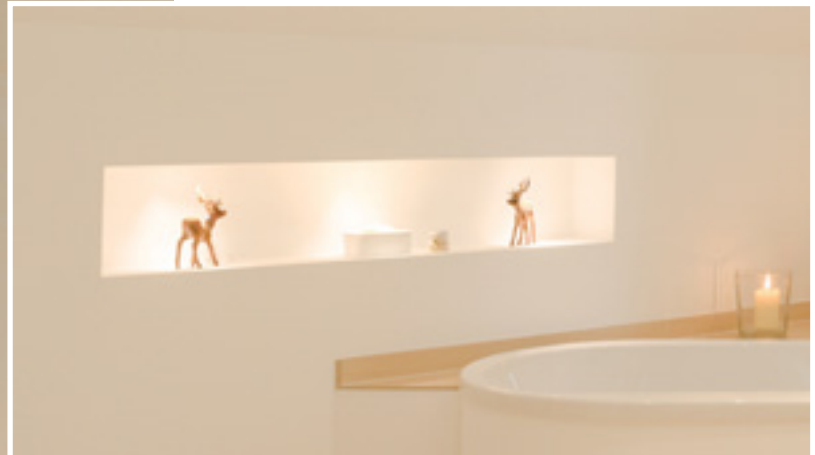

Niches

The space-saving solution

- Prefabricated elements
- Perfectly compatible with wall panel LUX ELEMENTS®-ELEMENT-EL
- Elegant option for storage
- Water- and mould-resistant
- Ready for tiling



For further information, please refer to our documents. Data sheets, test certificates and processing instructions can be downloaded from www.luxelements.com

Niches

Specifications

■ LUX ELEMENTS®-RELAX-NI-...

niches prefabricated from ELEMENT-EL 12

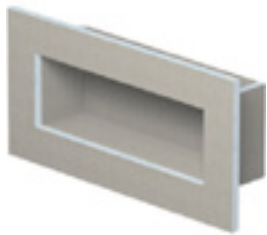

LUX ELEMENTS®-RELAX-NI-S

niche

external dimensions:
406 x 89 x 203 mm
16" x 3 1/2" x 8"

internal dimensions:
305 x 77 x 102 mm
11" x 3" x 4"



LUX ELEMENTS®-RELAX-NI-M

niche

external dimensions:
406 x 89 x 406 mm
16" x 3 1/2" x 16"

internal dimensions:
305 x 77 x 304 mm
11" x 3" x 11"

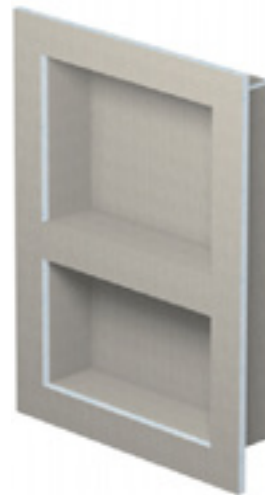

LUX ELEMENTS®-RELAX-NI-L

niche with one shelf

external dimensions:
406 x 89 x 559 mm
16" x 3 1/2" x 22"

internal dimensions:
305 x 77 x 457 mm
11" x 3" x 18"



LUX ELEMENTS®-RELAX-NI-XL

niche with two shelves

external dimensions:
406 x 89 x 1070 mm
16" x 3 1/2" x 42 1/8"

internal dimensions:
305 x 77 x 968 mm
11" x 3" x 38"

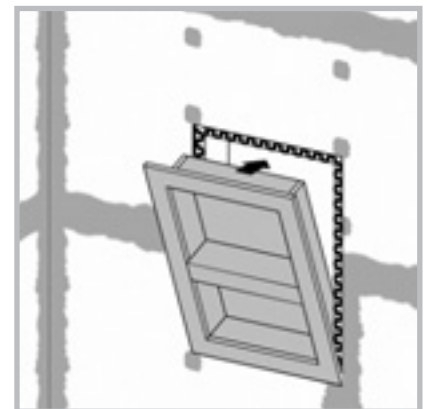
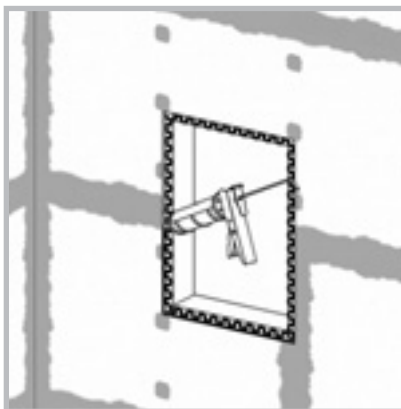
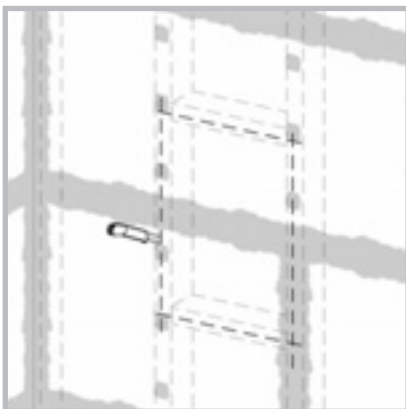



LUX ELEMENTS – WETROOM PRODUCTS

Secure. Fast. Individual.

Curbs and Ramps

Curbs – as water stop

Optional curbs between the shower and the floor are a suitable method of protecting the bathroom against splash-water from the shower.

LUX ELEMENTS has two standard curbs in different lengths for this purpose. The curbs can be adapted to fit any shower base dimensions by simply cutting to size.



Ramps – for creating a barrier-free shower area

Prefabricated ramps allow to create a barrier-free transition from bathroom floor to a shower base with a step (Step-Up).

LUX ELEMENTS has two standard ramps in two widths with different gradients. The ramps can be adapted to fit any shower base dimensions by simply cutting to size.



Curbs and Ramps

Specifications

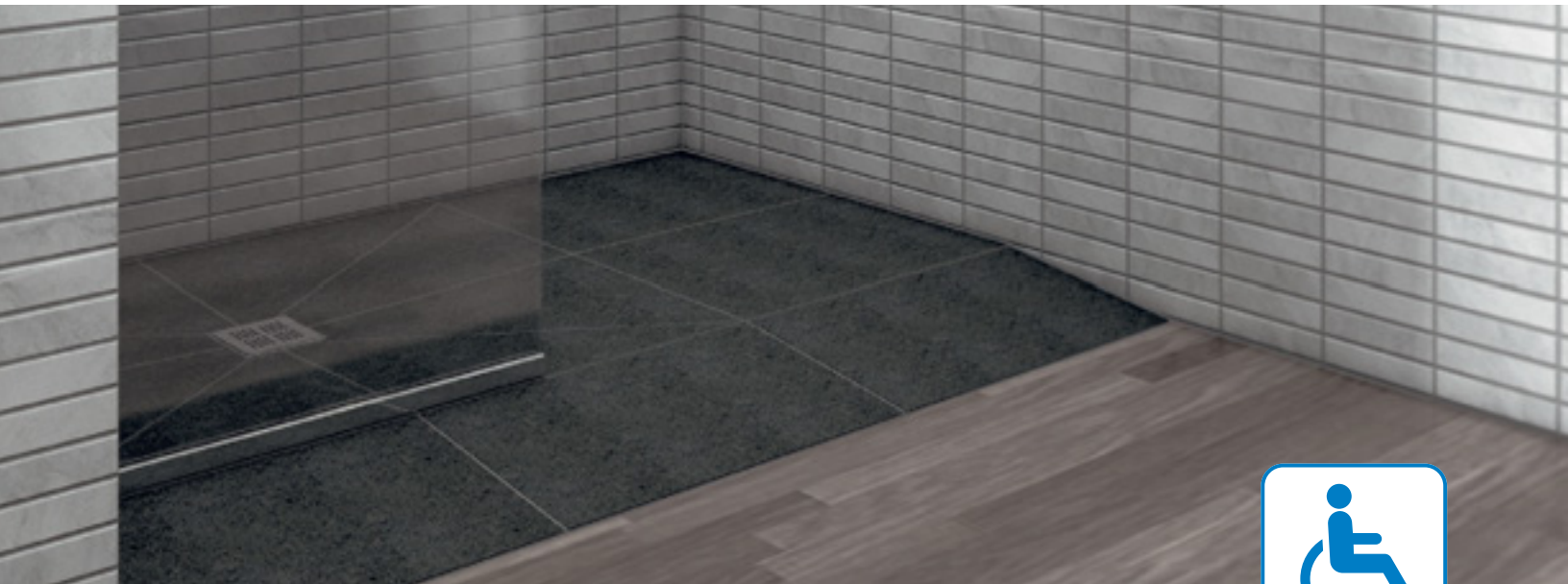

Please consult with technical support regarding installation instructions of ADA Accessibility Guidelines (ADAAG)

LUX ELEMENTS – WETROOM PRODUCTS

Secure. Fast. Individual.

■ Curbs

Many configurations can be achieved with LUX ELEMENTS®-RELAX-CU-F curbs.
Below are some examples:

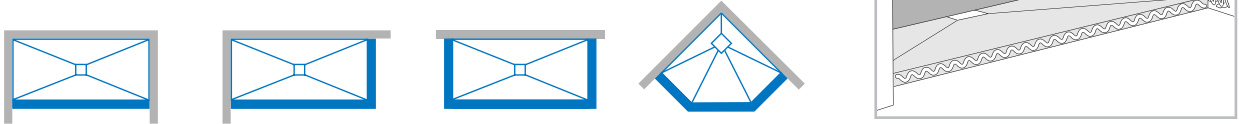

LUX ELEMENTS®-RELAX-CU-F 5

dimensions:
1524 x 114 x 130/127 mm
60" x 4 1/2" x 5 1/8"/5"



LUX ELEMENTS®-RELAX-CU-F 8

dimensions:
2444 x 114 x 130/127 mm
96" x 4 1/2" x 5 1/8"/5"

For further information, please refer to our documents. Data sheets, test certificates and processing instructions can be downloaded from www.luxelements.ca

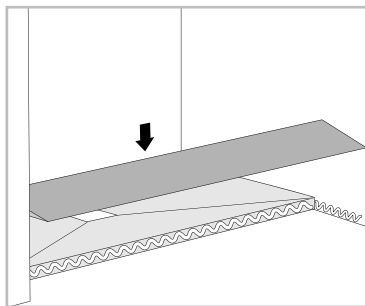

■ Ramps

LUX ELEMENTS®-RELAX-RP M

gradient 19,2 %, dimensions:
1828 x 204 x 45 mm
71 15/16" x 8 1/16" x 1 3/4"

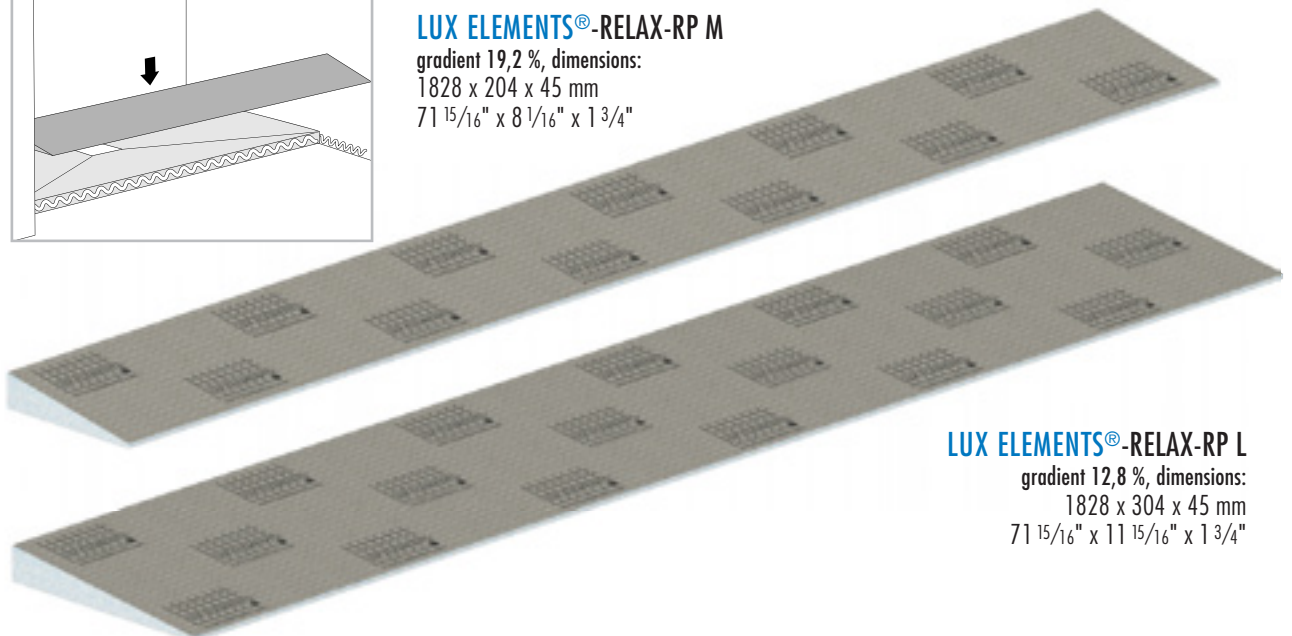

LUX ELEMENTS®-RELAX-RP L

gradient 12,8 %, dimensions:
1828 x 304 x 45 mm
71 15/16" x 11 15/16" x 1 3/4"



LUX ELEMENTS – WETROOM PRODUCTS

Secure. Fast. Individual.

Washstands in “floating design”

LAVADO-FLOAT are washstand models made of hard foam support material for individual tiling. An invisible suspension provides the four model variants with or without recess with a “floating design”.

The washstands can be shortened at the sides, which enables them to be adapted to smaller bathrooms. The construction of a row of washstands is also possible by means of arranging and gluing together several washstands.





- Individual design – Surface design freely selectable
- Easy to process – Prefabricated, ready for tiling
- Modern bathroom design with a “floating” look
- For every room situation – simple to shorten
- Double washstands and row constructions are easy to implement
- Ideally for barrier-free bathrooms

Washstands

Specifications

■ LUX ELEMENTS®-LAVADO-FLOAT – the principle

Hard foam support element
with fabric coating

Basin recess
with built-in slope

Assembly openings
for the simple assembly of drain and taps

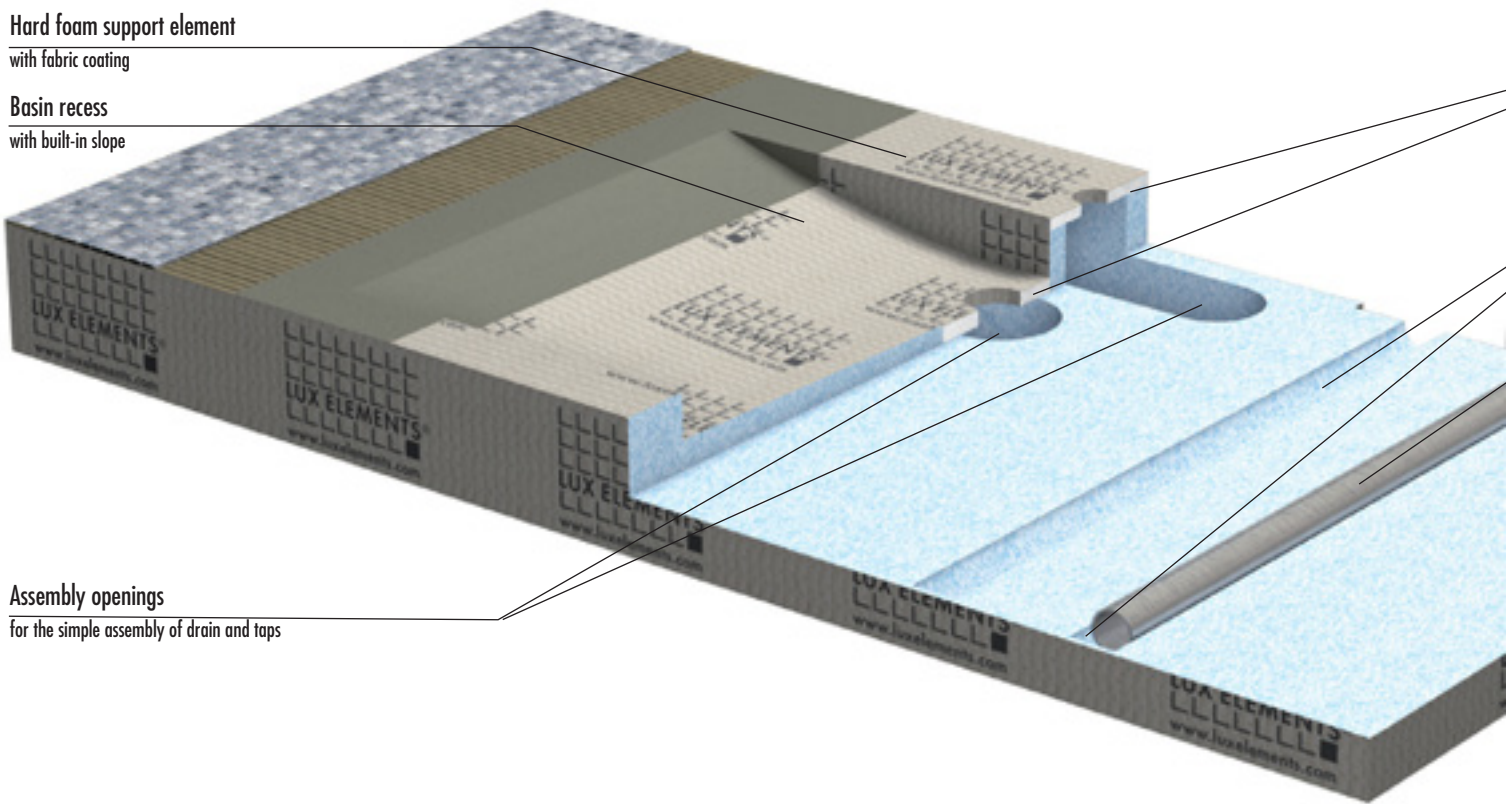

The installation of LAVADO-FLOAT is possible not only on masonry but also on stud frames

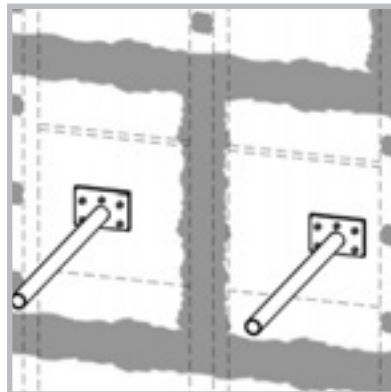
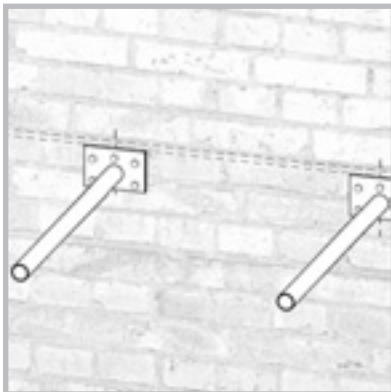

LUX ELEMENTS – WETROOM PRODUCTS

Secure. Fast. Individual.

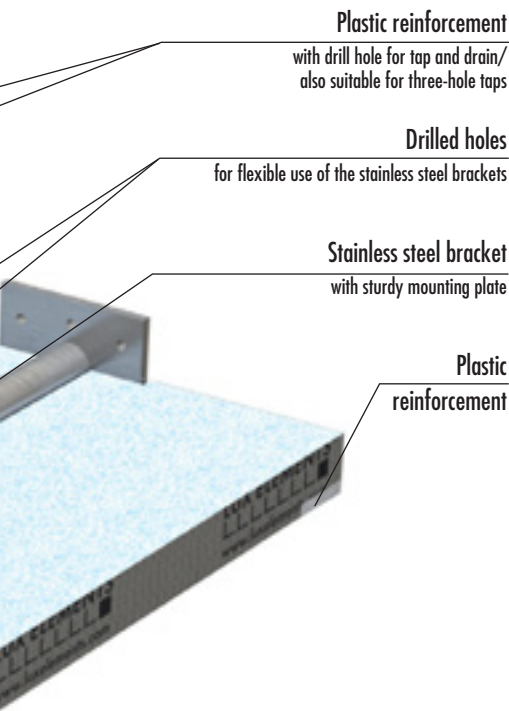

■ LAVADO-FLOAT – model variants

Washstands with invisible suspension as set for single washing facility, incl. 1 piece COL-MK and 2 stainless steel brackets 450 mm · 17¹¹/₁₆" in length.

LUX ELEMENTS®-LAVADO-FLOAT G

washstand, even, without recess
dimensions:
1170 x 585 x 100 mm
46 ¹/₁₆" x 23 ¹/₁₆" x 3 ¹⁵/₁₆"

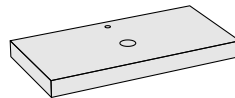

LUX ELEMENTS®-LAVADO-FLOAT E

washstand with elliptical recess
dimensions:
1170 x 585 x 100 mm
46 ¹/₁₆" x 23 ¹/₁₆" x 3 ¹⁵/₁₆"

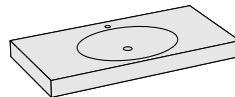

LUX ELEMENTS®-LAVADO-FLOAT R

washstand with rectangular recess
dimensions:
1170 x 585 x 100 mm
46 ¹/₁₆" x 23 ¹/₁₆" x 3 ¹⁵/₁₆"

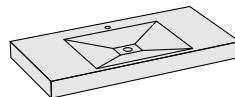

LUX ELEMENTS®-LAVADO-FLOAT Z

washstand with cylindrical recess
dimensions:
1170 x 585 x 100 mm
46 ¹/₁₆" x 23 ¹/₁₆" x 3 ¹⁵/₁₆"

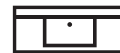
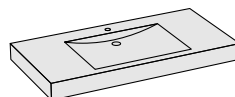

For further information, please refer to our documents. Data sheets, test certificates and processing instructions can be downloaded from www.luxelements.ca





LUX ELEMENTS – WETROOM PRODUCTS

Secure. Fast. Individual.

Individual Surface Design

Ceramic surfaces

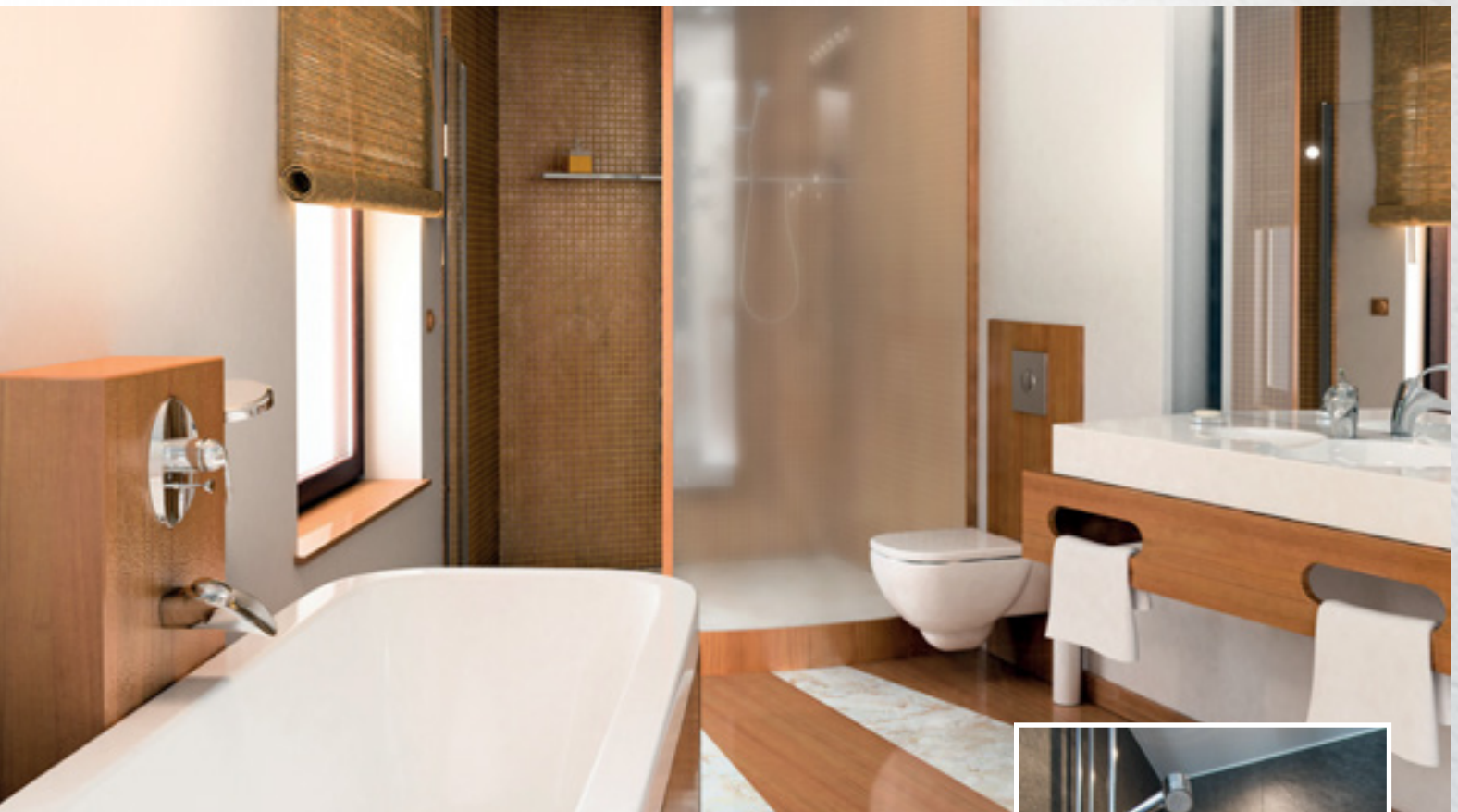

LUX ELEMENTS® hard foam support elements are the ideal substrate for tiles, because they offer optimum hold for cement-based adhesives and seals. Even more advantages of the hard foam support elements in systems with ceramics:

- **Emission-neutral,
i.e. no vapours that are detrimental to health**
- **No subsequent affect on ambient air**
- **Without solvents and neutral in smell**
- **Resistant to mould**
- **For mosaic tiles up to large-sized ceramics**

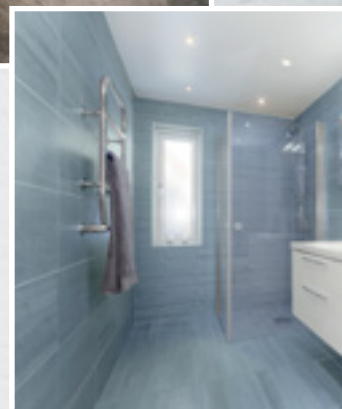
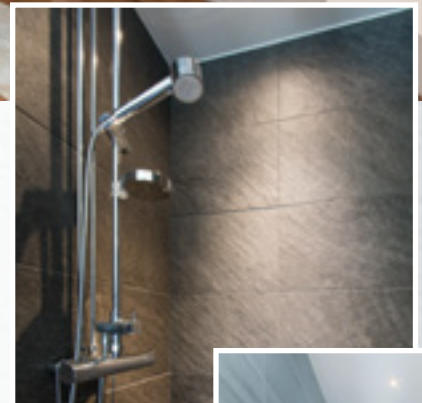



Individual Surface Design

Alternative surfaces: plasters

For further information, please refer to our documents. Data sheets, test certificates and processing instructions can be downloaded from www.luxelements.ca



LUX ELEMENTS® hard foam support elements are also the right substrate for plasters, as the mortar coating offers reliable adhesion.

- **Tested in systems by renowned plaster manufacturers**
- **Additional room for design is created even in combination with tiles**
- **Application is possible e.g. where tiles or mosaic cannot be installed due to curves.**

Whether on the wall, for constructions, in the shower area or on the floor – hard foam support elements from LUX ELEMENTS are the right substrate anywhere. Not only for large-sized ceramics and mosaic tiles, but also for plasters.



LLLLLLLLLL
LLLLLLLLLL
LLLLLLLLLL
LUX ELEMENTS®
LLLLLLLLLL
www.luxelements.ca



Installation videos on www.m.luxelements.com or visit our new
YouTube-Channel on www.youtube.com/user/luxelementscom

(D)

LUX ELEMENTS GmbH & Co. KG
An der Schusterinsel 7 · D - 51379 Leverkusen
Tel. +49 (0) 21 71/7212-0
Fax +49 (0) 21 71/7212-10
E-Mail info@luxelements.de
Web www.luxelements.com

(F)

LUX ELEMENTS S.A.S
31, rue d'Ensisheim · F - 68190 Ungersheim
Tél. +33 (0) 3 89 83 69 79
Fax +33 (0) 3 89 48 83 27
E-Mail info@luxelements.fr
Web www.luxelements.fr

